

Electricity and New Energy
Photovoltaic Systems

Course Sample

593987

Order no.: 593987 (Printed version) 594303 (CD-ROM)

First Edition

Revision level: 09/2018

By the staff of Festo Didactic

© Festo Didactic Ltée/Ltd, Quebec, Canada 2017

Internet: www.festo-didactic.com

e-mail: did@de.festo.com

Printed in Canada

All rights reserved

ISBN 978-2-89747-956-5 (Printed version)

ISBN 978-2-89747-958-9 (CD-ROM)

Legal Deposit – Bibliothèque et Archives nationales du Québec, 2017

Legal Deposit – Library and Archives Canada, 2017

The purchaser shall receive a single right of use which is non-exclusive, non-time-limited and limited geographically to use at the purchaser's site/location as follows.

The purchaser shall be entitled to use the work to train his/her staff at the purchaser's site/location and shall also be entitled to use parts of the copyright material as the basis for the production of his/her own training documentation for the training of his/her staff at the purchaser's site/location with acknowledgement of source and to make copies for this purpose. In the case of schools/technical colleges, training centers, and universities, the right of use shall also include use by school and college students and trainees at the purchaser's site/location for teaching purposes.

The right of use shall in all cases exclude the right to publish the copyright material or to make this available for use on intranet, Internet, and LMS platforms and databases such as Moodle, which allow access by a wide variety of users, including those outside of the purchaser's site/location.

Entitlement to other rights relating to reproductions, copies, adaptations, translations, microfilming, and transfer to and storage and processing in electronic systems, no matter whether in whole or in part, shall require the prior consent of Festo Didactic.

















Information in this document is subject to change without notice and does not represent a commitment on the part of Festo Didactic. The Festo materials described in this document are furnished under a license agreement or a nondisclosure agreement.

Festo Didactic recognizes product names as trademarks or registered trademarks of their respective holders.

All other trademarks are the property of their respective owners. Other trademarks and trade names may be used in this document to refer to either the entity claiming the marks and names or their products. Festo Didactic disclaims any proprietary interest in trademarks and trade names other than its own.

Safety and Common Symbols

The following safety and common symbols may be used in this course and on the equipment:

Symbol	Description
	DANGER indicates a hazard with a high level of risk which, if not avoided, will result in death or serious injury.
	WARNING indicates a hazard with a medium level of risk which, if not avoided, could result in death or serious injury.
	CAUTION indicates a hazard with a low level of risk which, if not avoided, could result in minor or moderate injury.
	CAUTION used without the <i>Caution, risk of danger</i> sign  , indicates a hazard with a potentially hazardous situation which, if not avoided, may result in property damage.
	Caution, risk of electric shock
	Caution, hot surface
	Caution, risk of danger. Consult the relevant user documentation.
	Caution, lifting hazard
	Caution, belt drive entanglement hazard
	Caution, chain drive entanglement hazard
	Caution, gear entanglement hazard
	Caution, hand crushing hazard
	Notice, non-ionizing radiation
	Consult the relevant user documentation.
	Direct current
	Alternating current

Safety and Common Symbols











Symbol	Description
	Both direct and alternating current
	Three-phase alternating current
	Earth (ground) terminal
	Protective conductor terminal
	Frame or chassis terminal
	Equipotentiality
	On (supply)
	Off (supply)
	Equipment protected throughout by double insulation or reinforced insulation
	In position of a bi-stable push control
	Out position of a bi-stable push control

Table of Contents

Preface	IX
About This Course	XI
To the Instructor	XIII
Introduction Photovoltaic Systems	1
COURSE OBJECTIVE	1
DISCUSSION OF FUNDAMENTALS	1
Stand-alone and grid-tied photovoltaic (PV) systems	1
Protection and disconnection components in PV systems	4
Exercise 1 Stand-Alone PV Systems for DC Loads	7
DISCUSSION	8
Introduction to stand-alone PV systems for dc loads	8
PV panel	8
Battery	9
Charge controller	12
Physical representation of a stand-alone PV system for dc loads	12
Operation of a stand-alone PV system for dc loads	13
Selection of the PV panel, charge controller, and battery for a specific stand-alone PV system	15
On-off charge controllers	16
Battery charging control method	16
Battery overdischarge protection	18
Topology	20
Power switching device technology	22
Pulse-width modulation (PWM) charge controllers	22
Battery charging control method	22
Battery overdischarge protection	25
Topology	25
Power switching device technology	25
Applications of stand-alone PV systems for dc loads	26
Electric power provision in small buildings	26
Battery charging in recreational vehicles	27
Refrigeration in developing countries	27
Lighting of public spaces	28
Road signaling	29
Effect of using energy-efficient electric equipment on the size and cost of stand-alone PV systems for dc loads	29

Table of Contents

PROCEDURE.....	30
Setup and connections	31
Emulated PV panel settings.....	32
Main components of a stand-alone PV system for dc loads	32
Setting up a stand-alone PV system for dc loads.....	35
Stand-alone PV system operation	37
PV panel producing no electricity.....	37
PV panel producing electricity at a rate below the power demand of the dc loads	39
PV panel producing electricity at a rate equal to the power demand of the dc loads	40
PV panel producing electricity at a rate exceeding the power demand of the dc loads.....	40
Battery charging.....	42
Comparing the energy consumption of two different types of dc lamps.....	44
Battery overdischarge protection	45
CONCLUSION.....	47
REVIEW QUESTIONS	48
Exercise 2 Use of an MPPT Charge Controller in Stand-Alone PV Systems.....	49
DISCUSSION	49
Introduction	49
MPPT charge controllers	49
Topology.....	50
Battery charging control method	53
Battery overdischarge protection	54
Power switching device technology	54
Operating point of the PV panel in stand-alone PV systems using an on-off or PWM charge controller	55
Operating point of the PV panel in stand-alone PV systems using an MPPT charge controller	56
Comparison of the on-off, PWM, and MPPT charge controllers	57
PROCEDURE.....	58
Setup and connections	58
Partial discharge of the battery pack	59
Emulated PV panel settings.....	60
Setting up a stand-alone PV system for dc loads.....	61
Operating point of the PV panel in a stand-alone PV system using a PWM charge controller	62
Operating point of the PV panel in a stand-alone PV system using an MPPT charge controller	66
CONCLUSION.....	70
REVIEW QUESTIONS	70

Table of Contents

Exercise 3	Stand-Alone PV Systems for AC Loads	73
	DISCUSSION	73
	Introduction to stand-alone PV systems for ac loads	73
	Physical representation of a stand-alone PV system for ac loads.....	75
	Selection of the PV panel, charge controller, battery, and stand-alone inverter for a specific stand-alone PV system ...	76
	Applications of stand-alone PV systems for ac loads.....	78
	Electric power provision in homes	79
	Electric power provision in small buildings	80
	Effect of using energy-efficient electric equipment on the size and cost of stand-alone PV systems for ac loads	80
	PROCEDURE.....	81
	Setup and connections	82
	Emulated PV panel settings.....	82
	Main components of a stand-alone PV system for ac loads	83
	Setting up a stand-alone PV system for ac loads.....	86
	Operation of the stand-alone inverter	88
	Comparing the energy consumption of different types of ac lamps.....	89
	Battery overdischarge protection function of the stand-alone inverter	91
	CONCLUSION.....	94
	REVIEW QUESTIONS	94
Exercise 4	Grid-Tied PV Systems	95
	DISCUSSION	95
	Introduction to grid-tied PV systems.....	95
	PV panel.....	96
	Grid-tied inverter.....	96
	Energy meter	97
	Operation of a grid-tied PV system.....	97
	PV panel/grid-tied inverter arrangements.....	99
	Central inverter	99
	String inverters	101
	Micro-inverters.....	103
	Physical representation of a grid-tied PV system.....	104
	Selection of the PV panel, grid-tied inverter, and energy meter for a specific grid-tied PV system	106
	Energy metering in grid-tied PV systems	108
	Net metering.....	108
	Gross metering.....	109

Table of Contents

Monitoring and setting the operation of micro-inverters	110
Effect of using energy-efficient electric equipment on grid-tied PV systems	111
Setup and connections	112
Emulated PV panel settings.....	113
Main components of a grid-tied PV system	113
Setting up a grid-tied PV system using gross metering.....	116
Operation of the grid-tied PV system using gross metering	118
Automatic disconnection of the grid-tied inverter during a power outage	122
Setting up a grid-tied PV system using net metering/self- consumption.....	123
Operation of the grid-tied PV system using net metering/self-consumption.....	124
CONCLUSION.....	125
REVIEW QUESTIONS	126
Appendix A Equipment Utilization Chart	129
Appendix B Glossary of New Terms	131
Appendix C Safe Handling of PV Panels	133
Appendix D Preparation of the 48V Lead-Acid Battery Pack.....	135
Charging procedure	135
Sulfation test	136
Battery maintenance.....	138
Appendix E Setting up the Communications Gateway	139
Index of New Terms	143
Acronyms	145
Bibliography.....	147

Preface

Electrical energy is part of our life since more than a century and the number of applications using electric power keeps increasing. This phenomenon is illustrated by the steady growth in electric power demand observed worldwide. In reaction to this phenomenon, the production of electrical energy using renewable natural resources (e.g., wind, sunlight, rain, tides, geothermal heat, etc.) has gained much importance in recent years since it helps to meet the increasing demand for electric power and is an effective means of reducing greenhouse gas (GHG) emissions.

To help answer the increasing needs for training in the wide field of electrical energy, Festo Didactic developed a series of modular courses. These courses are shown below as a flow chart, with each box in the flow chart representing a course.

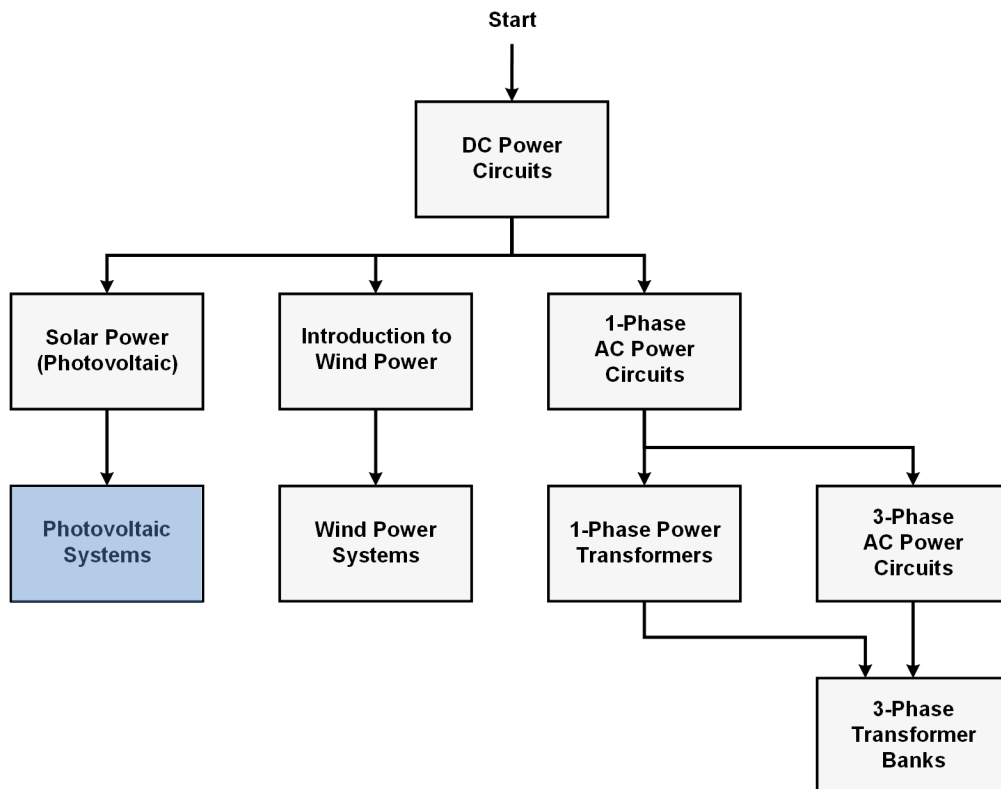

Festo Didactic courses in electrical energy.

Teaching includes a series of courses providing in-depth coverage of basic topics related to the field of electrical energy such as dc power circuits, ac power circuits, and power transformers. Other courses also provide in-depth coverage of solar power and wind power. Finally, two courses deal with photovoltaic systems and wind power systems, with focus on practical aspects related to these systems.

We invite readers to send us their tips, feedback, and suggestions for improving the course.

Please send these to did@de.festo.com.

The authors and Festo Didactic look forward to your comments.

About This Course

Climate changes observed throughout the world in recent years have led to an ever-growing demand for renewable sources of energy to counteract these changes and to help minimize their negative effects on our lives. Solar power is by far Earth's most available source of renewable energy, easily capable of providing many times the total current energy demand.

The present course discusses photovoltaic (PV) systems, i.e., systems that convert sunlight into electric power that can be used to power electrical equipment or feed the local ac power network. The course covers the major aspects of both stand-alone PV systems and grid-tied PV systems, paying special attention to the integration of the major components used in these systems. Several applications of PV systems are presented throughout the course. Finally, the course demonstrates the impact of using energy-efficient equipment on the size and cost of the PV system required in any specific application.



Home equipped with a photovoltaic (PV) system converting sunlight into electricity.

Safety considerations

Safety symbols that may be used in this course and on the equipment are listed in the Safety and Common Symbols table at the beginning of this document.

Safety procedures related to the tasks that you will be asked to perform are indicated in each exercise.

Make sure that you are wearing appropriate protective equipment when performing the tasks. You should never perform a task if you have any reason to think that a manipulation could be dangerous for you or your teammates.

Before performing manipulations with the equipment, you should read all sections regarding safety in the Safety Instructions and Commissioning manual accompanying the equipment.

About This Course

Prerequisite

As a prerequisite to this course, you should have completed courses *DC Power Circuits* and *Solar Power (Photovoltaic)*.

Systems of units

Units are expressed using the International System of Units (SI).

To the Instructor

You will find in this Instructor version of the course all the elements included in the Student version of the course together with the answers to all questions, results of measurements, graphs, explanations, suggestions, and, in some cases, instructions to help you guide the students through their learning process. All the information that applies to you is placed between markers and appears in red.

Accuracy of measurements

The numerical results of the hands-on exercises may differ from one student to another. For this reason, the results and answers given in this course should be considered as a guide. Students who correctly perform the exercises should expect to demonstrate the principles involved and make observations and measurements similar to those given as answers.

Equipment installation and use

In order for students to be able to safely perform the hands-on exercises in this course, the equipment must have been properly installed, i.e., according to the instructions given in the accompanying Safety Instructions and Commissioning manual. Also, the students must familiarize themselves with the safety directives provided in the Safety Instructions and Commissioning manual and observe these directives when using the equipment.

Sample
Extracted from
Instructor Guide

Stand-Alone PV Systems for DC Loads

EXERCISE OBJECTIVE

When you have completed this exercise, you will be familiar with the configuration and operation of stand-alone PV systems for dc loads. You will be able to verify that the PV panel, charge controller, and battery selected for a specific stand-alone PV system can work together without causing problems. You will understand how battery charging control and battery overdischarge protection work in on-off charge controllers. You will also understand how battery charging control and battery overdischarge protection work in PWM charge controllers. You will know several common applications of stand-alone PV systems for dc loads. Finally, you will understand that using energy-efficient electric equipment is a means of reducing the size and cost of the stand-alone PV system for dc loads required in any application.

DISCUSSION OUTLINE

The Discussion of this exercise covers the following points:

- Introduction to stand-alone PV systems for dc loads
PV panel. Battery. Charge controller.
- Physical representation of a stand-alone PV system for dc loads
- Operation of a stand-alone PV system for dc loads
- Selection of the PV panel, charge controller, and battery for a specific stand-alone PV system
- On-off charge controllers
Battery charging control method. Battery overdischarge protection. Topology. Power switching device technology.
- Pulse-width modulation (PWM) charge controllers
Battery charging control method. Battery overdischarge protection. Topology. Power switching device technology.
- Applications of stand-alone PV systems for dc loads
Electric power provision in small buildings. Battery charging in recreational vehicles. Refrigeration in developing countries. Lighting of public spaces. Road signaling.
- Effect of using energy-efficient electric equipment on the size and cost of stand-alone PV systems for dc loads

DISCUSSION

Introduction to stand-alone PV systems for dc loads

Figure 4 shows a simplified diagram of a stand-alone PV system for dc loads. The system consists of a PV panel, a battery, and a charge controller.

 Several elements, such as the PV panel blocking and bypass diodes, PV panel lightning surge arrester, PV panel fused disconnect switch, and load circuit-breaker panel, have been omitted in the simplified diagram of Figure 4 for the sake of clarity.

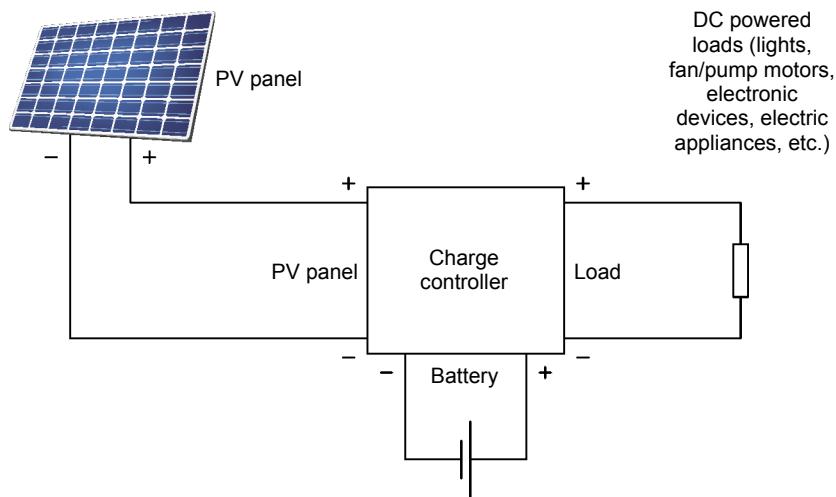



Figure 4. Simplified diagram of a stand-alone PV system for dc loads.

For each of the elements in the stand-alone PV system above, the remainder of this section states the function of the element, describes what the element consists of, and briefly explains how the element operates.

PV panel

The PV panel converts sunlight into electricity which takes the form of direct-current (dc) power. It can consist of a single panel or an array of panels connected in series, in parallel, or in series-parallel, as shown in Figure 5.

 Bypass and/or blocking diodes have been omitted in Figure 5 for the sake of clarity.

The solar irradiation is also commonly referred to as the solar irradiance.

A single PV panel is often sufficient in applications where the **daily energy demand** is low (e.g., a roadside information panel). On the other hand, an array of PV panels is generally used in applications where the daily energy demand is larger (e.g., energy provision for a home). Determining the size (power) of the PV panel required in a specific stand-alone PV system mainly depends on the daily energy demand (kWh/day) and the average value of the daily solar irradiation (kWh/m² - day) at the location the PV system is installed. It also depends on other parameters of lesser importance and is a fairly complex process which is beyond the scope of this course.

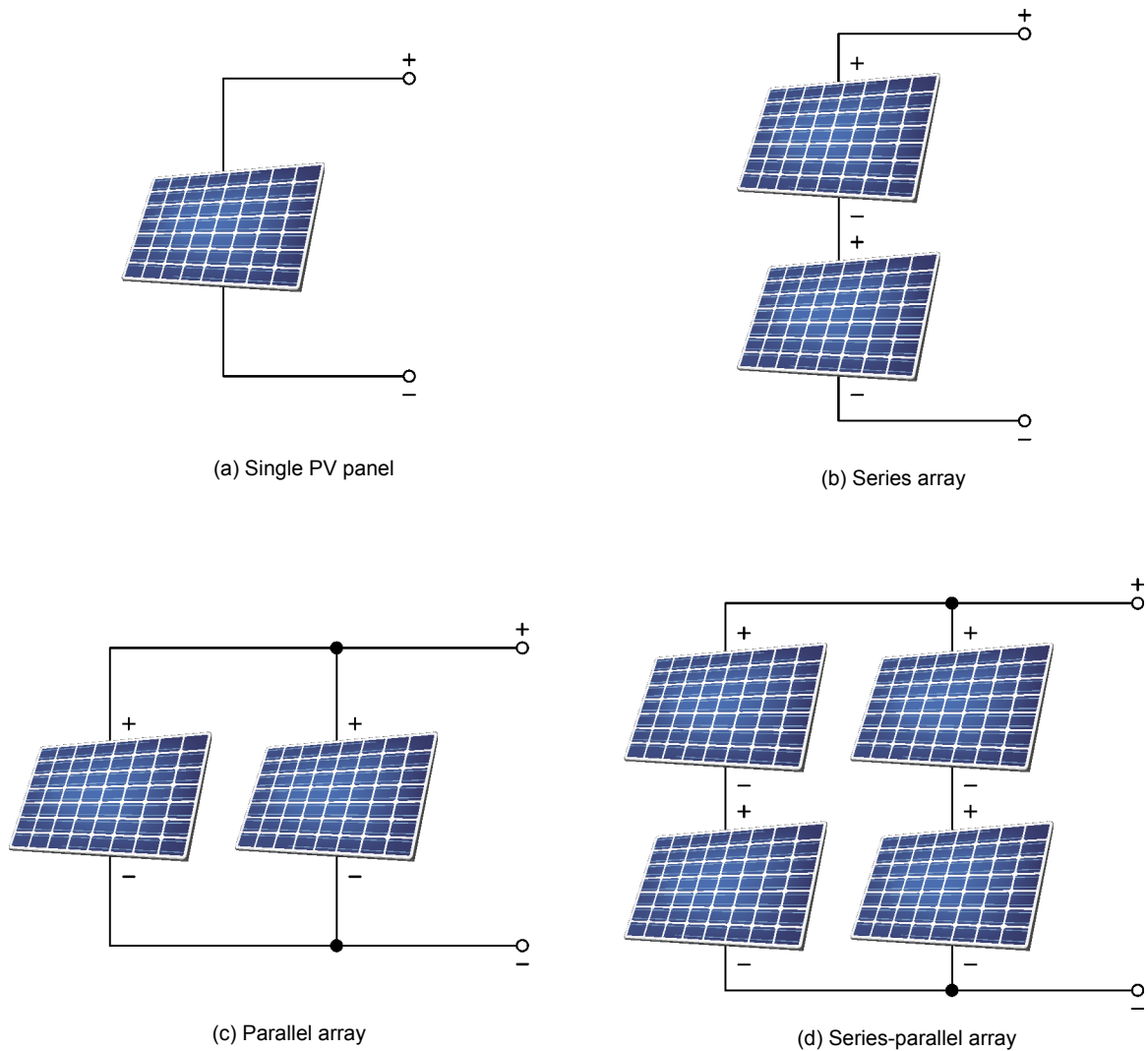

Figure 5. The PV panel can consist of a single panel or an array of panels connected in series, in parallel, or in series-parallel.

Battery

An array of batteries is commonly referred to as a battery bank.

The battery stores electricity produced by the PV panel. It consists of a single battery in low-power applications, or an array of batteries connected in series, in parallel, or in series-parallel in applications requiring more power. Deep-cycle lead-acid batteries are generally used in stand-alone PV systems because they can be discharged repeatedly to a large percentage (generally up to 80%) of their rated capacity without harm, although such repetitive deep discharges will likely shorten the battery life. Deep-cycle lead-acid batteries are also commonly used in stand-alone PV systems because they are cost effective.

The nominal voltage of the battery or battery bank in a stand-alone PV system is generally 12 V, 24 V, or 48 V. The battery voltage sets the voltage at which the PV system operates, and thus is commonly referred to as the system voltage. Figure 6 shows typical arrangements of battery banks resulting in system voltages of 12 V, 24 V, and 48 V.

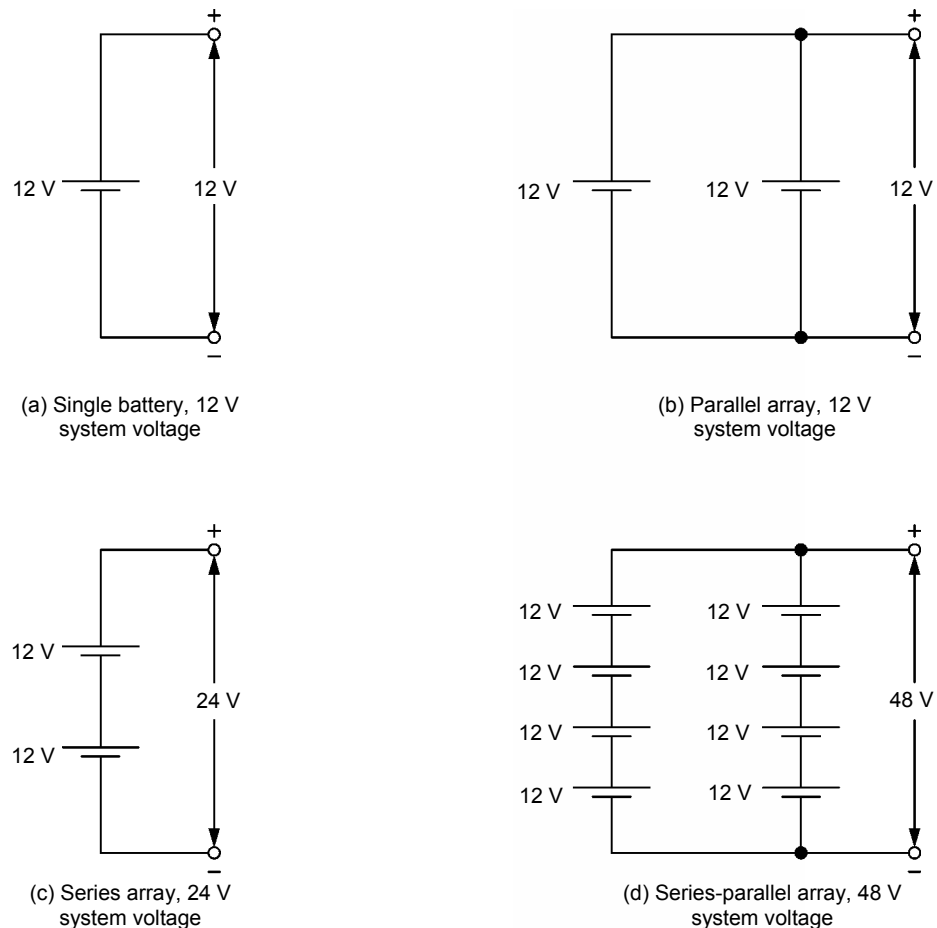

Figure 6. Typical arrangements of battery banks resulting in system voltages of 12 V, 24 V, and 48 V.

Connecting batteries in series increases the system voltage. Connecting batteries in parallel increases the system capacity (Ah), i.e., the amount of electricity that the stand-alone PV system can store. The larger the storage capacity, the longer the PV system can continue to supply power to the loads when the PV panel produces no or little electricity. The parameters listed below are the key factors used to determine the capacity (Ah) of the battery or battery bank required in a specific stand-alone PV system.

- Daily energy demand (kWh/day) of the loads.
- Average value of the daily solar irradiation (kWh/m² - day) at the location the PV system is installed.
- Desired system autonomy, i.e., the period (generally a given number of days) during which the stand-alone PV system should be able to supply power to the loads without the PV panel producing electricity.

Determining the capacity (Ah) of the battery required in a stand-alone PV system also depends on other parameters of lesser importance and is a fairly complex process which is beyond the scope of this course.

Figure 7 shows an ideal battery and its current-voltage (I-U) characteristic curve. The I-U curve is a vertical line showing that the voltage U across an ideal battery remains constant no matter the value of the current I flowing through the battery. In other words, an ideal battery acts like an ideal voltage source. The curve also reveals that the value of the voltage U is equal to the battery voltage U_{Batt} , i.e., the battery voltage when no current flows through the battery (in other words, the open-circuit voltage). Notice that the value of voltage U_{Batt} increases slowly when

the battery is charging, thereby causing the I-U curve to slide toward the right. Inversely, the value of voltage $U_{\text{Batt.}}$ decreases slowly when the battery is discharging, thereby causing the I-U curve to slide toward the left.



In the following figures, current I is considered to be of positive polarity when the battery is charging and of negative polarity when the battery is discharging.

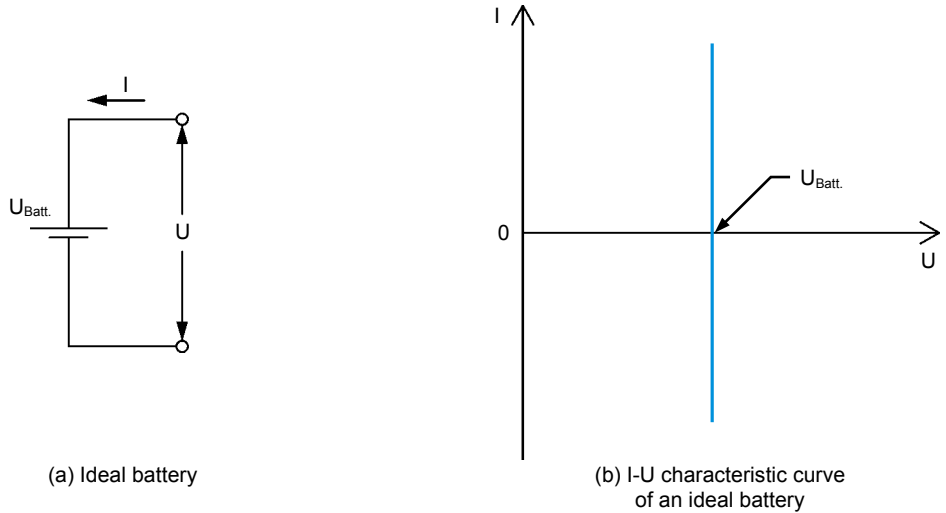

Figure 7. Ideal battery and its I-U characteristic curve.

Actual batteries, however, have internal resistance. Consequently, an actual battery is represented by an ideal battery connected in series with a resistor. Figure 8 shows the equivalent circuit of an actual battery and its current-voltage (I-U) characteristic curve. The I-U curve is a sloped line instead of a vertical line. This shows that the internal resistance causes the voltage U across an actual battery to vary with the value of the current I flowing through the battery.

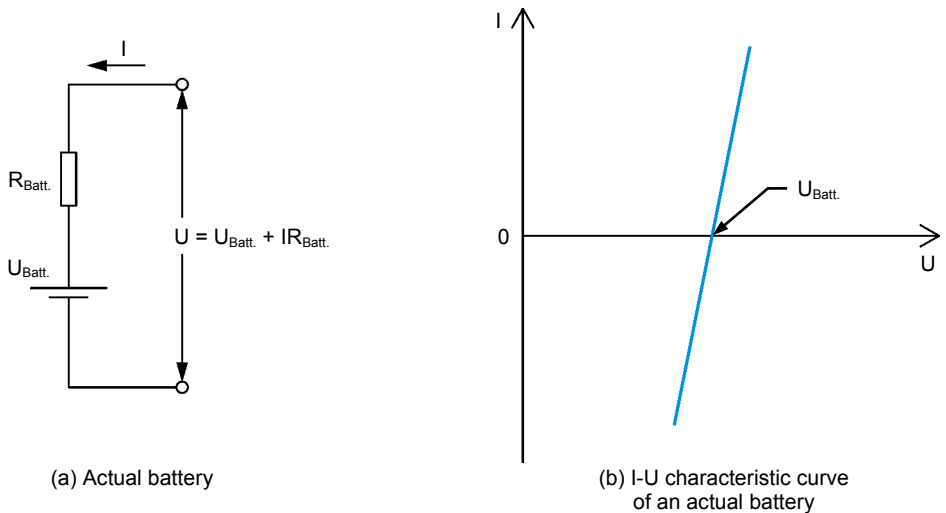

Figure 8. Equivalent circuit of an actual battery and resulting current-voltage (I-U) characteristic curve.

In fact, the voltage U across an actual battery is governed by the following equation, considering that current I is of positive polarity when the battery is charging.

$$U = U_{Batt.} + I \cdot R_{Batt.} \quad (1)$$

where $U_{Batt.}$ is the battery voltage when no current flows through the battery.

$R_{Batt.}$ is the resistance of the battery resistor.

This means that the voltage U across an actual battery is higher than the battery voltage $U_{Batt.}$ when the battery is charging and lower than the battery voltage $U_{Batt.}$ when the battery is discharging. Like an ideal battery, the value of voltage $U_{Batt.}$ increases slowly when the actual battery is charging, thereby causing the I-U curve to slide toward the right. Inversely, the value of voltage $U_{Batt.}$ decreases slowly when the actual battery is discharging, thereby causing the I-U curve to slide toward the left.

The I-U characteristic curve of actual batteries is useful to help understand the interaction between the PV panel, charge controller, and battery in a stand-alone PV system. This is studied later in this course.

Charge controller

The **charge controller** is a power control device that controls battery charging, prevents battery overcharging, and prevents the battery from being discharged too deeply. It uses electronic circuitry and power switching devices such as contact relays and/or electronic power switches to achieve the functions mentioned above. The charge controller is the “intelligent” device around which a stand-alone PV system is built. It generally has three distinct sets of terminals: one for the PV panel, one for the battery, and one for the dc powered loads.

The following three types of charge controller are commonly available on the market: on-off, PWM, and MPPT. The battery charging control method, topology, and power switching device technology are the main factors that differentiate these three types of charge controller. Each one of these three types of charge controller is further discussed later in this course.

Physical representation of a stand-alone PV system for dc loads

Figure 9 is an example of the physical representation of a stand-alone PV system for dc loads. In this example, the PV panel is installed on the roof of a building. The PV panel could also be installed on a support located close to the building. The charge controller and battery are generally located inside the building so they are protected from weather. The battery is located as close as possible to the charge controller in order to minimize the length of the interconnecting leads. Note that because the PV panel is installed outdoors, the leads connecting the PV panel to the charge controller are generally quite long (i.e., much longer than the leads connecting the battery to the charge controller).



Several elements, such as the PV panel blocking and bypass diodes, PV panel lightning surge arrester, PV panel fused disconnect switch, and load circuit-breaker panel, have been omitted in the simplified representation of Figure 9 for the sake of clarity.

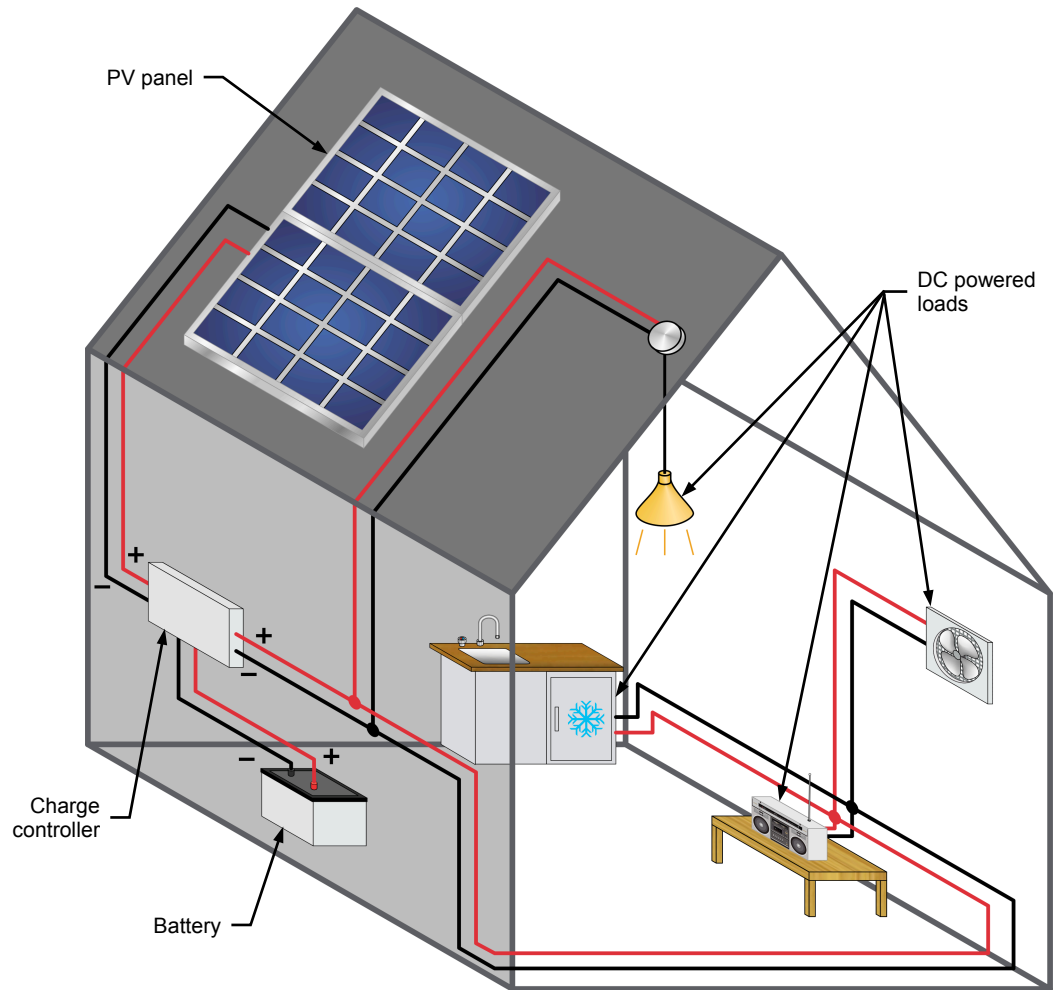

Figure 9. Simplified physical representation of a stand-alone PV system for dc loads.

Operation of a stand-alone PV system for dc loads

A stand-alone PV system for dc loads operates as follows. When sunlight strikes the PV panel, it produces electricity that is routed to the dc loads via the charge controller. Whenever the PV panel produces electricity at a rate exceeding the power demand of the dc loads, the charge controller uses the excess energy produced by the PV panel to charge the battery (when required), as shown in Figure 10. The charge controller automatically stops charging the battery or reduces the charge current to a very low value as soon as it detects that the battery is fully charged, thereby preventing battery overcharging.

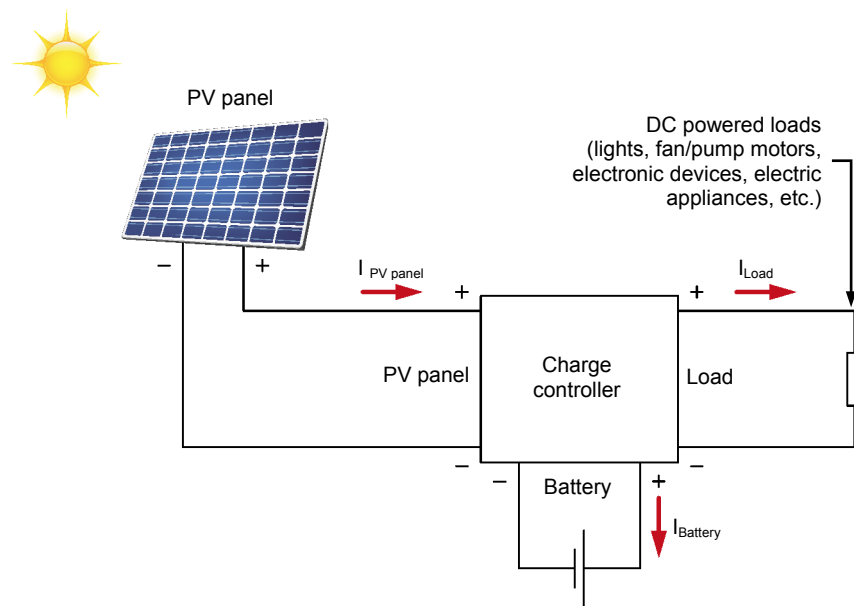

Figure 10. Daytime operation of a stand-alone PV system for dc loads when the PV panel produces electricity at a rate exceeding the power demand of the loads. This allows the battery to be charged when required.

When the PV panel produces no or little electricity, the charge controller continues to supply power to the dc loads using electricity drawn from the battery, as shown in Figure 11. The battery discharges slowly as it supplies power to the dc loads, thereby causing the battery voltage ($U_{Batt.}$) to decrease gradually. When the battery voltage decreases down to a certain value, the charge controller automatically disconnects the dc loads to prevent the battery from being discharged too deeply. Once the battery has recovered enough charge, the charge controller automatically reconnects the dc loads to the battery.

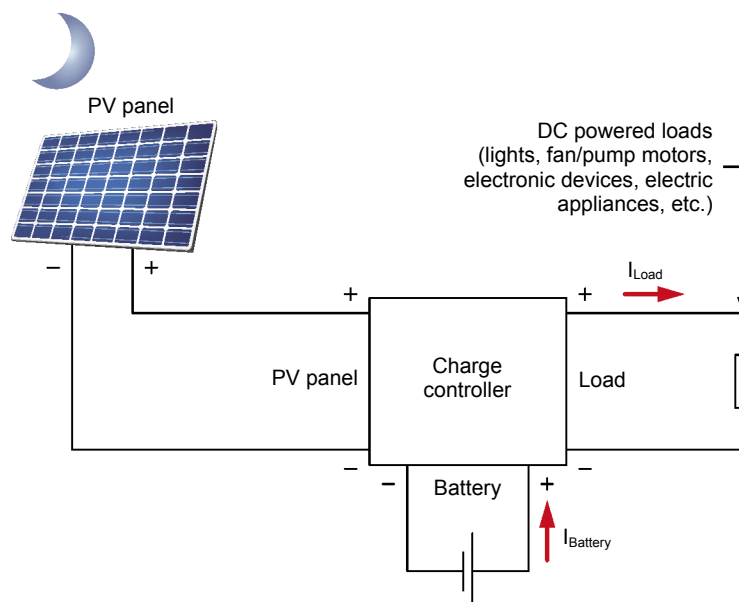

Figure 11. Nighttime operation of a stand-alone PV system for dc loads. The PV panel produces no electricity and all power supplied to the loads comes from the battery.

In brief, the charge controller is the centerpiece that manages power flow in any stand-alone PV system to ensure efficient and reliable operation. It is thus important to understand how the different types of charge controller available on the market operate. Operation of the on-off and PWM charge controllers is studied later in this discussion. Operation of the MPPT charge controller is studied in the discussion of the next exercise in this course.

Selection of the PV panel, charge controller, and battery for a specific stand-alone PV system

Table 1 presents the key specifications that must be considered when making sure that the PV panel, charge controller, and battery selected for a specific stand-alone PV system can work together without causing problems.

Table 1. Key specifications to be considered when making sure that the PV panel, charge controller, and battery selected for a specific stand-alone PV system can work together without problems.

Component	Specified parameter	Description of parameter
PV panel	Short-circuit current (I_{sc})	Current that flows through the PV panel when its terminals are short-circuited, measured under standard test conditions (STC).
	Open-circuit voltage (U_{oc})	Voltage which the PV panel produces when its terminals are left open, measured under standard test conditions (STC).
Charge controller	Maximum PV panel input current	Maximum current that can flow through the PV panel input terminals of the charge controller without causing overheating of the unit (and eventual damage to the unit).
	Maximum PV panel input voltage	Maximum voltage that can be applied across the PV panel input terminals of the charge controller without causing damage to the unit.
	System (load) voltage	Nominal voltage across the battery terminals and load terminals of the charge controller.
	Maximum load current	Maximum load current that can flow through the charge controller without causing overheating of the unit (and eventual damage to the unit).
Battery	Nominal voltage	Nominal voltage across the battery terminals.



In most charge controllers, the maximum PV panel input current and the maximum load current have the same value.

The following steps must be performed when making sure that the PV panel, charge controller, and battery selected for a specific stand-alone PV system can work together without causing problems.

1. The maximum PV panel input current of the charge controller must be larger than the short-circuit current (I_{sc}) of the PV panel. This ensures that the charge controller can route all the current which the PV panel can produce without overheating. In other words, this ensures that damage to the charge controller due to overheating cannot occur.

2. The maximum PV panel input voltage of the charge controller must be higher than the open-circuit voltage (U_{OC}) of the PV panel. This ensures that the PV panel cannot cause overvoltage at the PV panel input terminals of the charge controller (and ensuing damage to the controller). Note that the open-circuit voltage of the PV panel is measured under standard test conditions (STC) which stipulate a PV panel temperature of 25°C. The open-circuit voltage of a PV panel, however, decreases slightly as its temperature increases and vice versa. Consequently, when a stand-alone PV system is subject to operation in cold climate, the value of the open-circuit voltage of the PV panel must be corrected (to take the effect of temperature into account) before checking if the maximum PV panel input voltage of the charge controller is sufficient. For instance, let's consider a stand-alone PV system in which the PV panel temperature can be as low as -10°C during normal operation. The PV panel in this system has an open-circuit voltage of 80 V (under STC) which varies at a rate of -0.4%/°C. This results in an open-circuit voltage of 91.2 V at a temperature of -10°C. This is significantly higher than the specified open-circuit voltage of 80 V. The maximum PV panel input voltage of the charge controller, therefore, must be higher than 91.2 V (not 80 V) to ensure the PV panel cannot cause overvoltage.
3. The nominal voltage of the battery must be the same as the system (load) voltage. Naturally, all dc loads connected to the stand-alone PV system must be designed to operate at this voltage.
4. The system (load) voltage and maximum load current of the charge controller determine the maximum power that the stand-alone PV system can supply to the dc loads. The power rating of any one of the dc loads connected to the system must not exceed the maximum power that the system can supply, otherwise overheating of the charge controller will occur.

On-off charge controllers

On-off charge controllers are the oldest type of charge controller. They are cheaper than the other types of charge controller but provide lower battery charging performance that may reduce battery life. This section briefly explains how on-off charge controllers operate. It also presents two topologies commonly used in on-off charge controllers and states the types of power switching devices that are commonly used in these controllers.

Battery charging control method

The battery is charged by the current provided by the PV panel with no control of the magnitude of this current. The value of the charge current is simply equal to the value of the current the PV panel produces at the solar irradiation value at which it is operating. The on-off charge controller simply stops battery charging when the battery voltage reaches a certain value, called the voltage regulation (VR) setpoint, at which the battery is considered to be fully charged. The charge controller resumes battery charging when the battery voltage decreases to a certain value, called the voltage regulation reconnect (VRR) setpoint. Battery charging control in an on-off charge controller is illustrated in Figure 12.

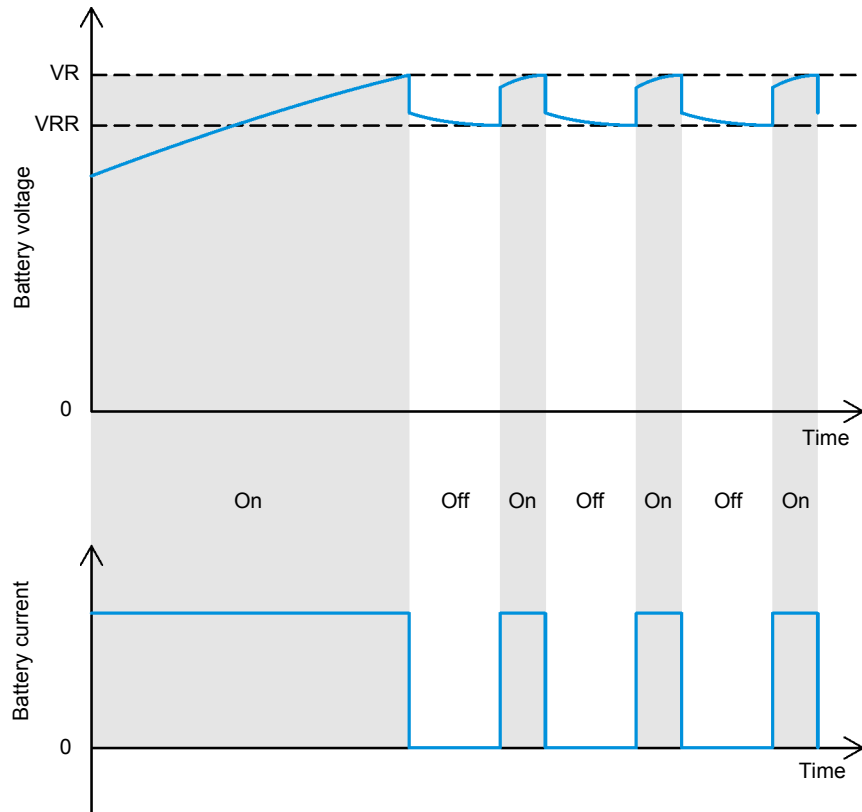

Figure 12. Battery charging control in an on-off controller.

Table 2 shows typical values of the VR and VRR setpoints that can be used in on-off charge controllers for various types of lead-acid batteries commonly available on the market. The values presented are for 12 V batteries. The values of the VR and VRR setpoints which the on-off charge controller uses to charge the battery whenever required are those given under the heading *Normal charge* in the table. Every 10 to 20 days, some on-off charge controllers perform an equalization charge of the battery. An equalization charge is simply a charging cycle that slightly overcharges the battery to equalize the state-of-charge of the battery cells. For this purpose, the values of the VR and VRR setpoints which the charge controller uses during an equalization charge (see heading *Equalization charge* in the table) are slightly higher than those used during a normal charge.



In on-off charge controllers that do not have the charge equalization feature, the values of the VR and VRR setpoints used during a normal charge may be increased slightly (generally by about 0.3 V to 0.6 V).

Table 2. Typical values of the VR and VRR setpoints that can be used in on-off charge controllers for various types of 12 V lead-acid batteries.

Type of lead-acid battery	Normal charge		Equalization charge	
	VR (V)	VRR (V)	VR (V)	VRR (V)
Flooded, vented	14.4	13.5	15.3	14.1
Flooded, sealed	14.4	13.5	15.0	13.8
AGM	14.1	13.2	14.4	13.5
GEL	14.1	13.2	14.7	13.5

The values of the VR and VRR setpoints used in a particular on-off charge controller are normally indicated in the documentation provided by the manufacturer.

Battery overdischarge protection

The on-off charge controller prevents overdischarge of the battery by disconnecting the load when the battery voltage decreases down to a certain value, called the low-voltage disconnect (LVD) setpoint. The controller automatically reconnects the loads when the battery voltage increases up to a certain value, called the low-voltage reconnect (LVR) setpoint. Battery overdischarge protection is illustrated in Figure 13.

The value of the LVD setpoint mainly depends on the maximum depth of discharge (DOD) recommended by the battery manufacturer. The value of the LVD setpoint is also influenced by the value of the discharge current that is expected. This is because the battery internal resistance makes the voltage across the battery decrease as the value of the discharge current increases. Table 3 shows approximate values of the LVD setpoint that can be used to implement battery overdischarge protection for different values of maximum DOD and discharge rate (i.e., discharge current expressed as a function of the battery capacity C). The values presented are for 12 V batteries. The higher the maximum DOD value that is acceptable, the lower the value of the LVD setpoint. Also, for any maximum DOD value, the higher the discharge rate expected, the lower the value of the LVD setpoint.

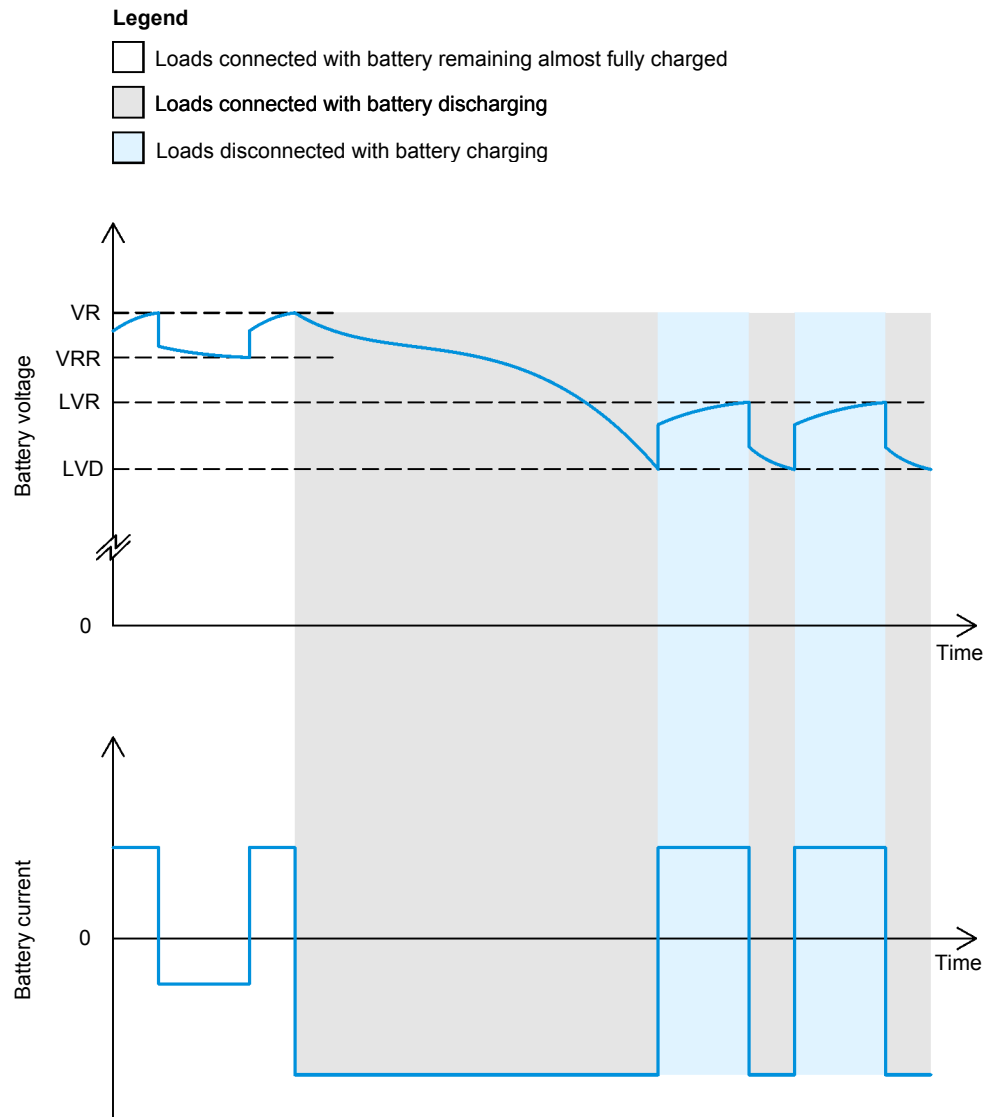

Figure 13. Battery overdischarge protection.

Table 3. Approximate values of the LVD setpoint that can be used to implement battery overdischarge protection for different values of maximum DOD and discharge rate (12 V batteries).

Maximum DOD (%)	LVD setpoint			
	@ C/200 (V)	@ C/60 (V)	@ C/20 (V)	@ C/10 (V)
20	12.8	12.7	12.5	12.4
30	12.7	12.6	12.4	12.3
40	12.5	12.5	12.3	12.2
50	12.4	12.3	12.2	12.1
60	12.2	12.1	12.0	11.9
70	12.0	11.9	11.9	11.8
80	11.8	11.8	11.7	11.5

The value of the LVR setpoint is mainly governed by the minimum state of charge (SOC) that the battery should recover before the load is reconnected. The value of the LVR setpoint is also influenced by the value of the charge current that is expected. This is because the battery internal resistance makes the voltage across the battery increase as the value of the charge current increases. Table 4 shows approximate values of the LVR setpoint that can be used to implement battery overdischarge protection for different values of minimum SOC and charge rate (i.e., charge current expressed as a function of the battery capacity C). The values presented are for 12 V batteries. The higher the minimum SOC value that is required before the loads are reconnected, the higher the value of the LVR setpoint. Also, for any minimum SOC value, the higher the charge rate expected, the higher the value of the LVR setpoint.

Table 4. Approximate values of the LVR setpoint that can be used to implement battery overdischarge protection for different values of minimum SOC and charge rate (12 V batteries).

Minimum SOC (%)	LVR setpoint			
	@ C/200 (V)	@ C/60 (V)	@ C/20 (V)	@ C/10 (V)
30	12.5	12.6	12.8	12.9
40	12.7	12.8	13.0	13.1
50	12.9	13.0	13.3	13.4
60	13.2	13.3	13.5	13.6
70	13.5	13.6	13.9	14.0
80	13.9	14.0	14.5	14.6

The values of the LVD and LVR setpoints used in a particular charge controller are normally indicated in the documentation provided by the manufacturer.

Topology

Stopping battery charging can be done by short-circuiting the PV panel. This is achieved by closing a power switching device connected in parallel with the PV panel, as shown in Figure 14. In this case, the charge controller is said to be of the shunt on-off type. Note that a blocking diode is required to prevent short-circuiting the battery when the PV panel is short-circuited by the power switching device. Battery overdischarge protection is achieved by opening a power switching device connected between the battery and the dc loads.

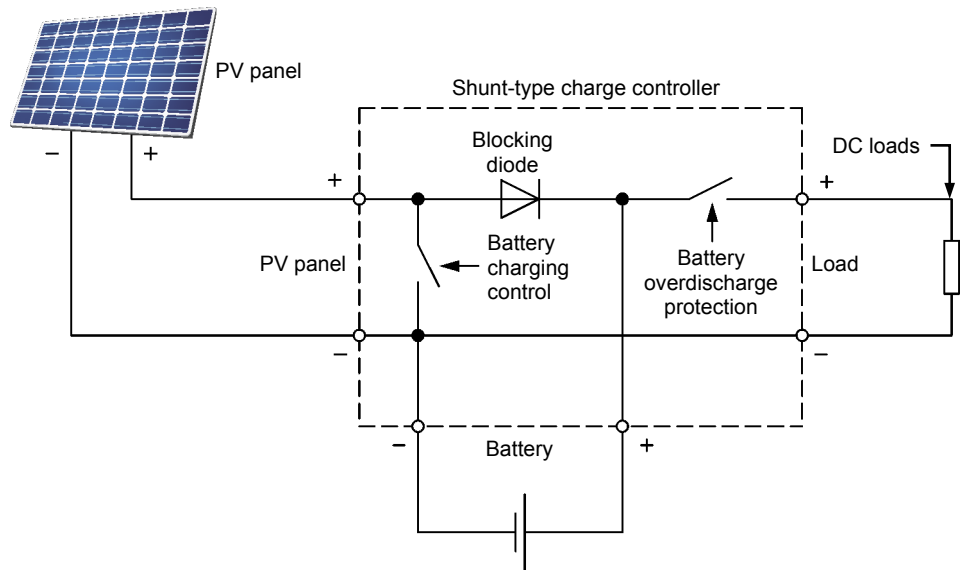

Figure 14. Topology of shunt-type charge controllers.

Stopping battery charging can also be done by disconnecting the PV panel from the battery. This is achieved by opening a power switching device connected between the PV panel and the battery, as shown in Figure 15. In this case, the charge controller is said to be of the series on-off type. A blocking diode may or may not be provided depending on the type of power switching device that is used in the charge controller. Battery overdischarge protection is achieved the same way as in a shunt-type charge controller, i.e., by opening a power switching device connected between the battery and the dc loads.

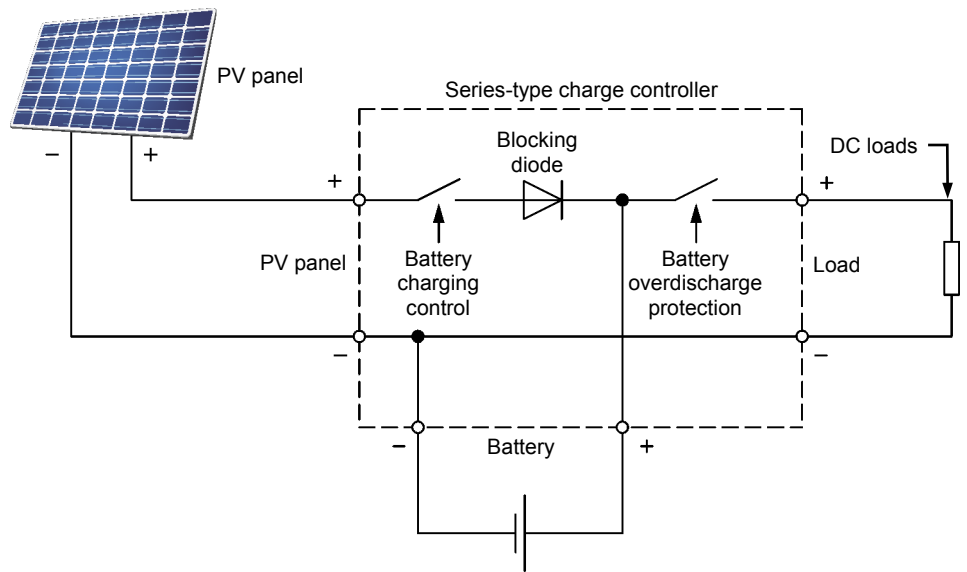

Figure 15. Topology of series-type charge controllers.

Power switching device technology

A contact relay, a **solid-state relay (SSR)**, or a power transistor of the **MOSFET** type is used in on-off charge controllers to implement battery charging. On the other hand, a contact relay or an SSR is used to implement battery overdischarge protection.

Pulse-width modulation (PWM) charge controllers

Design-wise, PWM charge controllers are newer than on-off charge controllers. This is particularly true of the battery charging control method used in PWM charge controllers. PWM charge controllers are more expensive than on-off charge controllers but provide better battery charging performance. This generally helps in maximizing battery life. This section briefly explains how PWM charge controllers operate. It also presents topologies commonly used in PWM charge controllers and states the types of power switching devices that are commonly used in these controllers.

Battery charging control method

The battery is charged by pulses of current provided by the PV panel. The PWM charge controller produces the pulses of current by momentarily stopping battery charging at a fast rate (e.g., 300 Hz). The PWM charge controller can adjust the width of the charge current pulses to change the average value of the charge current as required. This technique is referred to as **pulse-width modulation (PWM)**, hence the name PWM charge controller.

An example is shown in Figure 16. Large changes in the width of the charge current pulses are used in this example. This results in large step variations in the average value of the charge current that clearly demonstrate the effect which changing the width of the charge current pulses produces. Gradual variation of the average value of the charge current can be achieved by slightly varying the pulse width from one pulse of charge current to the next. Note that the amplitude A of the charge current pulses is equal to the value of the current produced by the PV panel. The value of this current depends on the size of the PV panel and the solar irradiation value at which the PV panel is operating. Consequently, the average value of the charge current can be adjusted to any value up to the amplitude A of the charge current pulses.

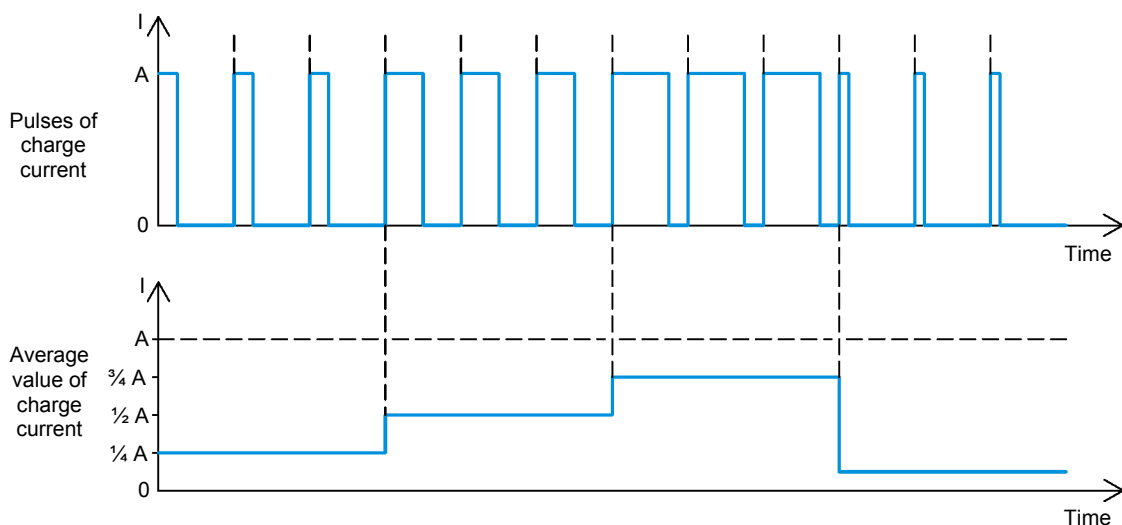

Figure 16. PWM charge controllers use pulse-width modulation (PWM) to adjust the average value of the charge current as required.

At the beginning of battery charging, maximum charge current is generally required. Consequently, charge current pulses of maximum width are required to make the average value of the charge current maximum (i.e., equal to the value of the current the PV panel is producing). In fact, most PWM charge controllers simply turn battery charging on (i.e., cease to momentarily stop battery charging to produce pulses of charge current) in order to make the average value of the charge current equal to the value of the current the PV panel is producing. This stage of battery charging is referred to as the bulk stage. The bulk stage of battery charging is in fact similar to battery charging using an on-off charge controller.

When the battery voltage reaches the voltage regulation (VR) setpoint, the PWM charge controller gradually decreases the average value of the charge current (by producing charge current pulses whose width decreases gradually) so that the battery voltage remains at the VR setpoint. This stage of battery charging is referred to as the absorption stage. The absorption stage allows the battery to be charged up to its nominal capacity C without affecting the battery life, something that most on-off charge controllers can hardly achieve.

When the average value of the charge current has decreased to a certain value, the PWM charge controller considers that the battery is fully charged, but continues battery charging using a lower voltage setpoint called the float voltage (V_{Float}). The PWM charge controller achieves this by adjusting the average value of the charge current (by adjusting the width of the charge current pulses) so that the battery voltage remains at the V_{Float} setpoint. This allows a charge current of low value to flow which maintains the full charge of the battery. This stage of battery charging is referred to as the float stage. The low charge current flowing during the float stage of battery charging is commonly referred to as the trickle current.

The three stages of this battery charging control method, which is commonly referred to as modified constant-voltage charging, are illustrated in Figure 17.

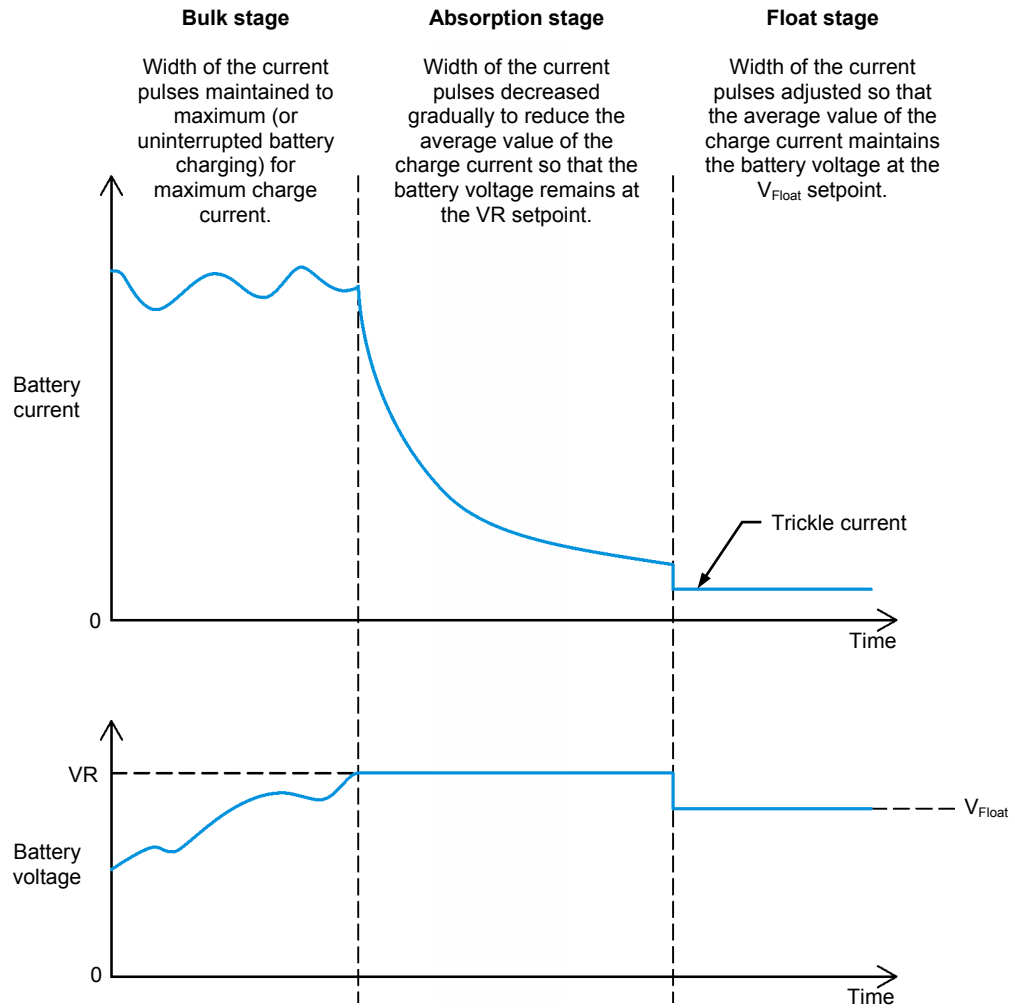

Figure 17. Modified constant-voltage charging used in PWM charge controllers.

Table 5 shows typical values of the VR and V_{Float} setpoints that can be used in PWM charge controllers for various types of lead-acid batteries commonly available on the market. The values presented are for 12 V batteries. The values of the VR and V_{Float} setpoints which the PWM charge controller uses to charge the battery whenever required are those given under the heading *Normal charge* in the table. Every 10 to 20 days, some PWM charge controllers perform an equalization charge of the battery. For this purpose, the value of the VR setpoint which the charge controller uses during an equalization charge (see heading *Equalization charge* in the table) is slightly higher than that used during a normal charge.

Table 5. Typical values of the VR and V_{Float} setpoints that can be used in PWM charge controllers for various types of 12 V lead-acid batteries.

Type of lead-acid battery	Normal charge		Equalization charge
	VR (V)	V_{Float} (V)	VR (V)
Flooded, vented	14.4	13.5	15.0
Flooded, sealed	14.7	13.8	15.0
AGM	14.1	13.5	14.4
GEL	14.4	13.5	14.7

In brief, battery charging in PWM charge controllers is better controlled than in on-off charge controllers. Consequently, PWM charge controllers are generally better than on-off charge controllers for optimizing battery capacity as well as for maximizing battery life.

Battery overdischarge protection

PWM charge controllers prevent overdischarge of the battery the same way as on-off charge controllers. Refer to section *On-off charge controllers* of this discussion for more detail.

Topology

PWM charge controllers use the same topologies as on-off charge controllers. When the shunt-type topology is used (see Figure 14 in the previous section), battery charging is momentarily stopped (to produce pulses of charge current) by closing a power switching device connected in parallel with the PV panel at a fast rate. In this case, the charge controller is said to be of the shunt PWM type. On the other hand, when the series-type topology is used (see Figure 15 in the previous section), battery charging is momentarily stopped by opening a power switching device connected between the PV panel and the battery at a fast rate. In this case, the charge controller is said to be of the series PWM type. In both topologies, battery overdischarge protection is achieved by opening a power switching device connected between the battery and the dc loads.

Power switching device technology

A solid-state relay (SSR) or a power transistor of the MOSFET type is used in PWM charge controllers to implement battery charging. On the other hand, a contact relay or an SSR is used to implement battery overdischarge protection.

Applications of stand-alone PV systems for dc loads

Stand-alone PV systems for dc loads are used in a variety of applications. This section describes some common applications of stand-alone PV systems for dc loads.

Electric power provision in small buildings

Stand-alone PV systems for dc loads are commonly used to provide dc power to low-power electric equipment in small buildings that are not connected to the grid (e.g., farm buildings, green houses, etc.) or that are in remote locations (e.g., hunting/fishing cabins, mountain refuges, etc.). The dc powered equipment in this type of application generally consist of low-power devices such as lighting fixtures, fan/pump motors, refrigerators, AM/FM radios, etc.



Figure 18. Small cabin powered by a stand-alone PV system.

Battery charging in recreational vehicles

Several low-power electrical devices (lighting fixtures, fan/pump motors, refrigerator, LP gas detector, etc.) in a recreational vehicle (RV) operate from dc power. A deep-cycle, lead-acid battery supplies dc power to these devices when the RV is not connected to an ac power outlet. A charge controller in the RV can use electricity produced by a PV panel to supply dc power to these devices and keep the battery charged. In this case, the dc power system in an RV operates exactly like a stand-alone PV system for dc loads. Note that when the RV is connected to an ac power outlet, the charge controller can draw power from the grid and convert it to dc power to supply the dc powered devices and keep the battery charged.



Figure 19. In recreational vehicles, PV panels can be used to supply electricity to dc powered devices and keep the battery charged.

Refrigeration in developing countries

In developing countries, keeping the vaccines and blood required to take care of the local population is challenging because electric power is not always available, or if available, may be subject to interruptions. DC powered refrigerators supplied by stand-alone PV systems are a very effective means of keeping vaccines and blood in these countries.

Lighting of public spaces

Some lighting systems for public spaces, such as streets, gardens, public transportation stops, etc., operate from dc power produced by stand-alone PV systems. In such systems, each light fixture is provided with its own stand-alone PV system. Solar-powered lighting systems do not require connection to the grid nor wires to route power from one light fixture to the next.



Figure 20. Solar-power street lighting system.

Road signaling

Similarly to lighting systems for public spaces, some road signaling devices, such as traffic lights, illuminated stop signs, roadside information panels, etc., operate from dc power produced by their own stand-alone PV system.



Figure 21. Solar-power traffic lights.

Effect of using energy-efficient electric equipment on the size and cost of stand-alone PV systems for dc loads

The daily energy demand (expressed in Wh/day or kWh/day) of each of the various loads that a stand-alone PV system has to supply must be considered to establish the total daily energy demand that is expected. The daily energy demand of a load is established by multiplying the power rating (expressed in W or kW) of the load by the time (expressed in hours) the load is expected to be used every day. The higher the total daily energy demand that is expected, the larger the size (in terms of either rated power or current capacity) of the PV panel, electronic devices (e.g., the charge controller), and battery required in the stand-alone PV system to ensure that the demand is met. This has a direct impact on the cost of the stand-alone PV system since the cost of each of these components increases with size. Consequently, reducing the total daily energy demand is highly desirable because it reduces the size, and thus the cost, of the stand-alone PV system required in any application.

Reduction in the total daily energy demand can be done by reducing the time of use of the loads. However, this alternative is limited, and sometimes it is simply not applicable. Reduction in the total daily energy demand can also be achieved by using electric equipment that is energy efficient, i.e., loads that require less power to perform the same task. For instance, using LED lamps instead of

conventional incandescent lamps for lighting is a good means of reducing the total daily energy demand, and thus, the size of a stand-alone PV system for dc loads. This is because an LED lamp generally uses about 5 to 7 times less energy than a conventional incandescent lamp to produce an equivalent amount of light.

In conclusion, let's consider a cabin where two 60 W incandescent lamps are judged sufficient for lighting. Considering that the lamps are lit 4 hours a day, this results in a daily energy demand of 480 Wh. On the other hand, using LED lamps that are assumed to consume 5 times less energy than the incandescent lamps results in a daily energy demand of 96 Wh, a substantial reduction of 384 Wh in the total daily energy demand. Over a complete year, this represents a reduction in the total energy demand of about 140 kWh.



Figure 22. LED lamps use about 5 to 7 times less energy than conventional incandescent lamps to produce an equivalent amount of light.

PROCEDURE OUTLINE

The Procedure is divided into the following sections:

- Setup and connections
- Emulated PV panel settings
- Main components of a stand-alone PV system for dc loads
- Setting up a stand-alone PV system for dc loads
- Stand-alone PV system operation
 - PV panel producing no electricity. PV panel producing electricity at a rate below the power demand of the dc loads. PV panel producing electricity at a rate equal to the power demand of the dc loads. PV panel producing electricity at a rate exceeding the power demand of the dc loads.*
- Battery charging
- Comparing the energy consumption of two different types of dc lamps
- Battery overdischarge protection

PROCEDURE

WARNING



High voltages are present in this laboratory exercise. Do not make or modify any banana jack connection with the power on unless otherwise specified.

Setup and connections

In this section, you will set up and connect the equipment required to perform the exercise.

1. Refer to the Equipment Utilization Chart in Appendix A to obtain the list of equipment required to perform this exercise.

Install the equipment in the workstation. You will use this equipment later in this exercise to set up a stand-alone PV system for dc loads.



Before continuing this exercise, measure the open-circuit voltage of the 48V Lead-Acid Battery Pack. If the open-circuit voltage is lower than 51.2 V, ask your instructor for assistance as the 48V Lead-Acid Battery Pack is probably not fully charged. Appendix D indicates how to fully charge the 48V Lead-Acid Battery Pack before a lab period.

Make the connections required to earth the equipment properly.



If necessary, check with the instructor to ensure that the connections you made provide proper earthing of the equipment.

2. Make sure that the main power switch of the 4 Quadrant Power Supply and Dynamometer Controller is set to the **O** (off) position, then connect its *Power Input* to an ac power outlet that is properly protected.

Make sure that the main power switch of the AC 24V Power Supply is set to the **O** (off) position, then connect its *Power Input* to an ac power outlet that is properly protected.



If necessary, check with the instructor to ensure that the ac power outlets to which you connect the equipment are properly protected.

3. Connect the *Power Input* of the Data Acquisition and Control Interface to the AC 24V Power Supply.
4. Ask your instructor to turn on (i.e., to unlock) electric power at your workstation, if applicable.
5. Turn the AC 24V Power Supply on.
6. Turn the 4 Quadrant Power Supply and Dynamometer Controller on, then set the *Operating Mode* switch to *Power Supply*.
7. Connect the USB port of the Data Acquisition and Control Interface to a USB port of the host computer.

Connect the USB port of the 4 Quadrant Power Supply and Dynamometer Controller to a USB port of the host computer.

8. Turn the host computer on, then start the LVDAC-EMS software.

In LVDAC-EMS, make sure that the [Data Acquisition and Control Interface](#) and the [4 Quadrant Power Supply and Dynamometer Controller](#) are detected. Make sure that the [Computer-Based Instrumentation \(two phases\)](#) function for the [Data Acquisition and Control Interface](#) is available. Also make sure that the [Solar Panel Emulator](#) function for the [4 Quadrant Power Supply and Dynamometer Controller](#) is available. Select the network voltage and frequency that correspond to the voltage and frequency of your local ac power network.

Emulated PV panel settings

In this section, you will set the size of the emulated PV panel that will be used to implement a stand-alone PV system for dc loads.

9. In LVDAC-EMS, do the settings required to make the [Four-Quadrant Power Supply and Dynamometer Controller](#) operate as a solar (PV) panel emulator. Then, set the solar panel emulator as follows:
- Number of PV modules in series: 8
 - Number of PV modules in parallel: 16
 - Solar irradiance control: manual (slider)
 - Solar irradiance: 1000 W/m²

The settings above set the size of the emulated PV panel to 8 PV modules in series and 16 PV modules in parallel. The output terminals of the power supply in the [Four-Quadrant Power Supply and Dynamometer Controller](#) are the terminals of the emulated PV panel.

At the moment, do not start the solar panel emulator. This prevents the emulated PV panel from producing electricity even if the solar irradiation is currently set to 1000 W/m².

Main components of a stand-alone PV system for dc loads

In this section, you will gather the key specifications of the emulated PV panel, [48V Lead-Acid Battery Pack](#), [DC 48V PWM Charge Controller](#), and [DC 48V Lamps](#) module. You will then use these specifications to verify that these pieces of equipment can work together without causing problems.

10. Observe that the electrical specifications of each PV module in the emulated PV panel are indicated in LVDAC-EMS.



In the remainder of this exercise, the emulated PV panel is also simply referred to as the PV panel.

According to the information provided in LVDAC-EMS, what are the short-circuit current (I_{sc}) and open-circuit voltage (U_{oc}) of the emulated PV panel, at a solar irradiation of 1000 W/m²?

Short-circuit current (I_{sc}): _____ A

Open-circuit voltage (U_{oc}): _____ V

Short-circuit current (I_{sc}): $16 \times 106 \text{ mA} = 1.70 \text{ A}$

Open-circuit voltage (U_{oc}): $8 \times 9.7 \text{ V} = 77.6 \text{ V}$

11. In **LVDAC-EMS**, start the solar panel emulator. This makes the emulated PV panel produce electricity because the solar irradiation is currently set to 1000 W/m².

In **LVDAC-EMS**, enable continuous refresh of the meters (dc voltmeter and ammeter, power meter, and energy meter) on the solar panel emulator. Observe that the voltage which the emulated PV panel produces is equal to the open-circuit voltage (about 78 V). This is normal because the terminals of the emulated PV panel (i.e., the output terminals of the power supply in the **4 Quadrant Power Supply and Dynamometer Controller**) are currently open.

The voltage which certain PV panels produce when their terminals are left open can be high enough to cause severe electric shocks. Therefore, care must always be exercised when manipulating PV panels (more specifically the connection terminals of PV panels). Appendix C provides information on the safe handling of PV panels.

In **LVDAC-EMS**, stop the solar panel emulator.

12. Observe the **48V Lead-Acid Battery Pack**. Notice that it consists of 4 sealed lead-acid batteries connected in series.



*In the remainder of this exercise, the **48V Lead-Acid Battery Pack** is also referred to as the battery.*

What are the battery voltage and battery capacity?

Battery voltage: _____ V

Battery capacity: _____ Ah

Battery voltage: 48 V

Battery capacity: 9 Ah

13. Table 6 provides the main specifications of the **DC 48V PWM Charge Controller**.

Table 6. Main specifications of the DC 48V PWM Charge Controller.

Parameter	Value
Maximum PV panel input current	7 A
Maximum PV panel input voltage	100 V
System voltage	48 V
Maximum load current	7 A

Based on the above specifications, can the DC 48V PWM Charge Controller be used with the emulated PV panel? Explain briefly.



Assume that the minimum operating temperature of the PV panel is 25°C.

Yes. The maximum PV panel input current (7 A) of the DC 48V PWM Charge Controller is well above the short-circuit current (1.70 A) of the emulated PV panel. Consequently, overcurrent at the PV panel input of the DC 48V PWM Charge Controller cannot occur. Also, the maximum PV panel input voltage (100 V) of the DC 48V PWM Charge Controller is significantly higher than the open-circuit voltage (77.6 V) of the emulated PV panel. Consequently, overvoltage cannot occur at the PV panel input of the DC 48V PWM Charge Controller.



In fact, the maximum current (7 A) of the DC 48V PWM Charge Controller is rather high compared to the short-circuit current (1.7 A) of the emulated PV panel. Consequently, it can also be used with a PV panel having a significantly larger short-circuit current.

Does the DC 48V PWM Charge Controller match the battery (system) voltage?

Yes No

Yes

What is the maximum amount of power which the DC 48V PWM Charge Controller can deliver to loads?

336 W, i.e., 7 A @ 48 V

14. Observe the DC 48V Lamps module. The voltage rating of the incandescent lamp and the LED lamp in the DC 48V Lamps module is 48 V. Are these lamps compatible with the battery (system) voltage?

Yes No

Yes

Note the power rating of the incandescent lamp and the LED lamp in the DC 48V Lamps module. Can the DC 48V PWM Charge Controller supply dc power to these lamps without a problem? Explain briefly.

Yes, because the maximum amount of power (336 W) which the DC 48V PWM Charge Controller can deliver to dc loads largely exceeds the power rating of the incandescent lamp and the LED lamp (60 W and 10 W, respectively) in the DC 48V Lamps module.

Setting up a stand-alone PV system for dc loads

In this section, you will set up a stand-alone PV system for dc loads using the Data Acquisition and Control Interface, emulated PV panel, 48V Lead-Acid Battery Pack, DC 48V PWM Charge Controller, and DC 48V Lamps module.



In the remainder of this exercise, the DC 48V PWM Charge Controller is also simply referred to as the PWM charge controller.

15. Use the Data Acquisition and Control Interface, emulated PV panel, 48V Lead-Acid Battery Pack, DC 48V PWM Charge Controller, and DC 48V Lamps module to set up the stand-alone PV system for dc loads shown in the diagram of Figure 23. In this system, the dc loads consist of the incandescent lamp and the LED lamp in the DC 48V Lamps module. The battery, the PV panel, and the dc loads should be connected to the PWM charge controller in the proper order. Proceed as follows to connect these components to the PWM charge controller.
 - First, connect the 48V Lead-Acid Battery Pack to the *Battery* terminals of the PWM charge controller via current input *I1* of the Data Acquisition and Control Interface. On the 48V Lead-Acid Battery Pack, close the circuit breaker by setting its lever to the *I* (on) position. The PWM charge controller turns on and performs a short start-up routine as soon as the circuit breaker closes. Observe the middle LED (battery status LED) in the set of three LEDs on the PWM charge controller. This LED indicates the battery's state of charge (LED lit in green = full charge, LED lit in orange = middle charge, LED lit in red = low charge, LED blinking red = fully discharged). The battery status LED should be lit in green if the battery is fully charged, as requested at the beginning of the exercise.
 - Then, connect the emulated PV panel to the *PV panel* terminals of the PWM charge controller.
 - Finally, connect the dc loads (incandescent and LED lamps in the DC 48V Lamps module) to the *Load* terminals of the PWM charge controller via current input *I2* of the Data Acquisition and Control Interface. Before making the connections, make sure that the lamp switches on the DC 48V Lamps module are set to the *O* (off) position. This prevents load current from flowing, and arcing from occurring, when the lamps are connected to the PWM charge controller.

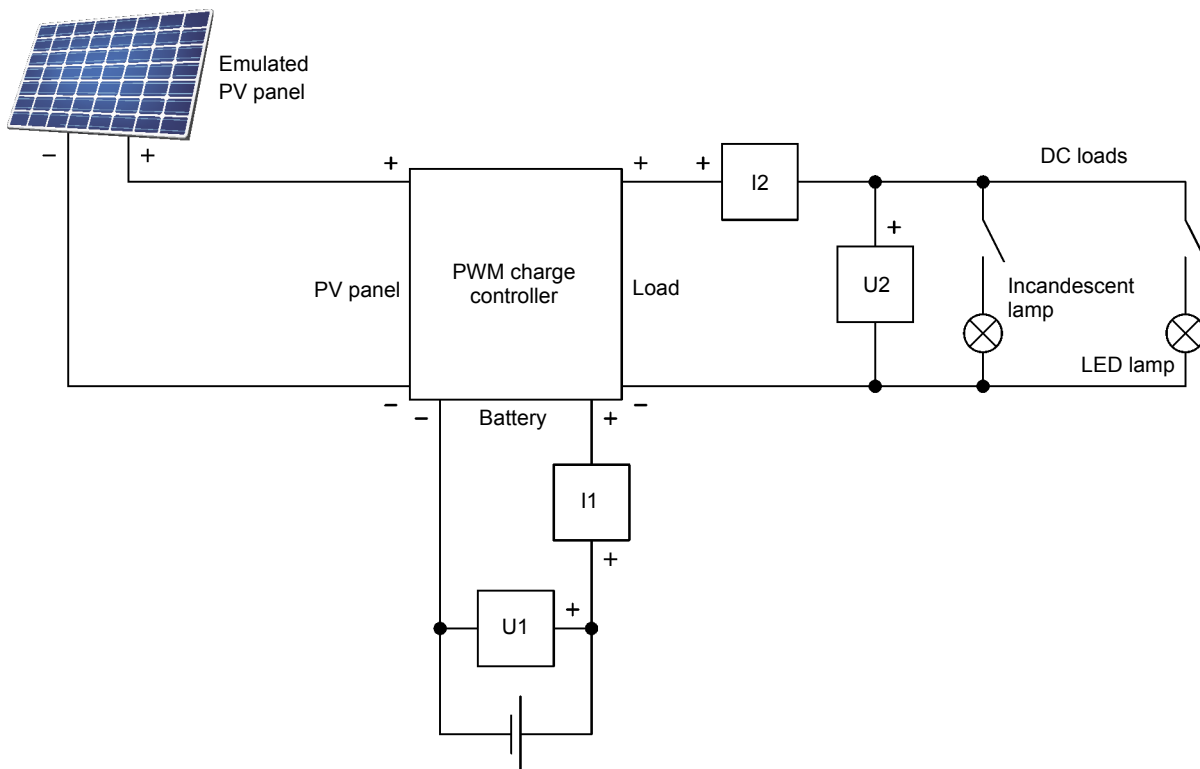

Figure 23. Stand-alone PV system for dc loads.

16. Several work modes are available in the PWM charge controller. The work mode determines the way in which the PWM charge controller manages the load. The selected work mode is indicated by a letter or a digit appearing for a few seconds in the *Work Mode* display of the PWM charge controller whenever the *ON/OFF/SET* button is depressed briefly. The work mode desired in this exercise is identified by the letter “C”. In this work mode, the charge controller automatically disconnects the load when the battery voltage becomes too low, thereby preventing battery overdischarge.

On the PWM charge controller, depress the *ON/OFF/SET* button briefly using a pencil and observe the letter or the digit that appears in the *Work Mode* display. If the letter “C” appears in the *Work Mode* display, go to the next step of the procedure since the desired work mode is selected in the PWM charge controller. Otherwise, continue the present step of the procedure.

On the PWM charge controller, depress the *ON/OFF/SET* button using a pencil until the letter or the digit in the *Work Mode* display begins to blink. Then, repeatedly depress and release the *ON/OFF/SET* button until the letter “C” appears in the *Work Mode* display.



*The work mode of the PWM charge controller can only be changed when the letter or digit in the *Work Mode* display is blinking.*

17. Observe that the right-hand side LED (load status LED) in the set of three LEDs on the PWM charge controller is lit. This indicates that dc power is available at the *Load* terminals of the PWM charge controller.

On the *DC 48V Lamps* module, turn the incandescent lamp on. Observe that the incandescent lamp lights up, thereby confirming that dc power is available at the *Load* terminals of the PWM charge controller.

18. In **LVDAC-EMS**, start the solar panel emulator.

Observe the left-hand side LED (charging stage LED) in the set of three LEDs on the PWM charge controller. This LED indicates the stage of battery charging the controller is in (LED off = no charge, LED blinking fast = bulk stage, LED lit continuously = absorption stage, LED blinking slowly = float stage). The charging stage LED should blink at a fast rate, thereby indicating that the controller is in the bulk stage of battery charging.

19. In **LVDAC-EMS**, observe that the dc voltmeter and ammeter of the solar panel emulator indicate the PV panel voltage and current. Notice that the polarity of the ammeter on the solar panel emulator is arranged so that the value of the measured current is positive when the PV panel produces electricity (i.e., when current exits through the positive terminal of the PV panel).

In **LVDAC-EMS**, set meters to measure the following parameters:

- Average (dc) value of the battery voltage (input *U1*)
- Average (dc) value of the battery current (input *I1*)
- Average (dc) value of the load voltage (input *U2*)
- Average (dc) value of the load current (input *I2*)

The voltmeter and ammeter (PV panel voltage and current) of the solar panel emulator as well as the meters set in **LVDAC-EMS** will be used throughout the exercise to monitor the operation of the stand-alone PV system for dc loads.

With the polarity of the ammeter on the solar panel emulator and the polarity of the two ammeters set in **LVDAC-EMS** (i.e., the polarity of current inputs *I1* and *I2* of the **Data Acquisition and Control Interface** shown in the diagram of Figure 23), the following equation relates the load current (I_{Load}) to the PV panel current (I_{PV}) and battery current (I_{Batt}).

$$I_{Load} = I_{PV} + I_{Batt}.$$

Make sure that continuous refresh of the meters is enabled in **LVDAC-EMS**.

Stand-alone PV system operation

In this section, you will observe the operation of the stand-alone PV system for dc loads at various values of solar irradiance.

PV panel producing no electricity

20. In **LVDAC-EMS**, set the solar irradiance of the solar panel emulator to 0 W/m². Observe that the charging stage LED on the PWM charge controller goes out to indicate that the battery is no longer charging.

Record the values of the dc voltage and current at the PV panel indicated by the voltmeter and ammeter of the solar panel emulator. Also record the values of the dc voltage and current at the battery and load indicated by the meters set in LVDAC-EMS.

PV panel voltage: _____ V

PV panel current: _____ A

Battery voltage: _____ V

Battery current: _____ A

Load voltage: _____ V

Load current: _____ A

PV panel voltage: 0.0 V

PV panel current: 0.0 A

Battery voltage: 50.0 V

Battery current: 1.20 A

Load voltage: 49.6 V

Load current: 1.15 A



The battery current is slightly larger than the load current. This is because the battery provides the load current as well as the current required for the operation of the PWM charge controller. The operating current of the PWM charge controller ranges from 0.05 A to 0.08 A, approximately.

Do the values of dc current at the PV panel, battery, and load indicate that the battery provides all load current? Explain briefly.

Yes. $I_{Load} = I_{PV} + I_{Batt.}$. Consequently, I_{Load} equals $I_{Batt.}$ when I_{PV} is 0 A.

What is the polarity of the battery current? What does this indicate?

The polarity of the battery current is positive, thereby indicating that current exits the positive terminal of the battery. In other words, this indicates that the battery is discharging.



For reasons of practicality, the polarity convention used to measure the battery current in this exercise is the inverse of the one used in the discussion to present the battery I-U curve.

Observe that the load voltage and the battery voltage have virtually the same value. Briefly explain why.



The load voltage is slightly less than the battery voltage because of the voltage drop (about 0.4 V) across the PWM charge controller and the connection leads.

In a stand-alone PV system for dc loads, the battery voltage sets the system voltage, and thus, the load voltage.

Let the system operate for about 10 to 15 minutes in order to slightly discharge the battery. Ideally, the battery voltage should have decreased to about 49.7 V before continuing the exercise.

PV panel producing electricity at a rate below the power demand of the dc loads

21. In LVDAC-EMS, slowly increase the solar irradiance of the solar panel emulator to about 300 W/m² while observing the values of the various currents. Observe that the value of the battery current decreases as that of the PV panel current increases. Also observe that the value of the load current remains virtually the same.

On the PWM charge controller, observe that the charging stage LED blinks at a fast rate, thereby indicating that the controller is in the bulk stage of battery charging.



The PWM charge controller enters the bulk stage of battery charging when it detects that the PV panel produces electricity. However, battery charging does not actually begin because the solar irradiation is too low.

In LVDAC-EMS, adjust the solar irradiance of the solar panel emulator so that the values of the PV panel current and battery current are approximately equal.

Record the values of the dc voltage and current at the PV panel indicated by the voltmeter and ammeter of the solar panel emulator. Also record the values of the dc voltage and current at the battery and load indicated by the meters set in LVDAC-EMS.

PV panel voltage: _____ V

PV panel current: _____ A

Battery voltage: _____ V

Battery current: _____ A

Load voltage: _____ V

Load current: _____ A

PV panel voltage: 49.9 V

PV panel current: 0.61 A

Battery voltage: 49.9 V

Battery current: 0.61 A

Load voltage: 49.6 V

Load current: 1.15 A



The sum of the PV panel current and battery current is slightly larger than the load current. This is because the PV panel and the battery provide the load current as well as the current required for the operation of the PWM charge controller. The operating current of the PWM charge controller ranges from 0.05 A to 0.08 A, approximately.

Do the values of dc current at the PV panel, battery, and load indicate that the PV panel and the battery each provide half of the load current? Explain briefly.

Yes. I_{PV} equals $I_{Batt.}$. Consequently, $I_{Load} = I_{PV} + I_{Batt.} = 2I_{PV} = 2I_{Batt.}$.

PV panel producing electricity at a rate equal to the power demand of the dc loads

22. In LVDAC-EMS, increase the solar irradiance of the solar panel emulator until the value of the battery current is approximately zero.

Record the values of the dc voltage and current at the PV panel indicated by the voltmeter and ammeter of the solar panel emulator. Also record the values of the dc voltage and current at the battery and load indicated by the meters set in LVDAC-EMS.

PV panel voltage: _____ V

PV panel current: _____ A

Battery voltage: _____ V

Battery current: _____ A

Load voltage: _____ V

Load current: _____ A

PV panel voltage: 50.5 V

PV panel current: 1.22 A

Battery voltage: 50.5 V

Battery current: 0.00 A

Load voltage: 50.3 V

Load current: 1.15 A



The PV panel current is slightly larger than the load current. This is because the PV panel provides the load current as well as the current required for the operation of the PWM charge controller. The operating current of the PWM charge controller ranges from 0.05 A to 0.08 A, approximately.

Do the values of dc current at the PV panel, battery, and load indicate that the PV panel provides all load current? Explain briefly.

Yes. $I_{Load} = I_{PV} + I_{Batt.}$. Consequently, I_{Load} equals I_{PV} when $I_{Batt.}$ is 0 A.

PV panel producing electricity at a rate exceeding the power demand of the dc loads

23. In LVDAC-EMS, increase the solar irradiance of the solar panel emulator so that the polarity of the battery current becomes negative. What does this indicate?

The negative polarity of the battery current indicates that current enters the positive terminal of the battery. In other words, this means that the battery is charging.

In **LVDAC-EMS**, set the solar irradiance of the solar panel emulator to 1000 W/m².

Record the values of the dc voltage and current at the PV panel indicated by the voltmeter and ammeter of the solar panel emulator. Also record the values of the dc voltage and current at the battery and load indicated by the meters set in **LVDAC-EMS**.

PV panel voltage: _____ V

PV panel current: _____ A

Battery voltage: _____ V

Battery current: _____ A

Load voltage: _____ V

Load current: _____ A

PV panel voltage: 51.1 V

PV panel current: 1.61 A

Battery voltage: 51.0 V

Battery current: -0.38 A

Load voltage: 50.8 V

Load current: 1.16 A



The PV panel current is slightly larger than the combined values of the load current and the battery charging current. This is because the PV panel provides the load current, the battery charging current, and the current required for the operation of the PWM charge controller. The operating current of the PWM charge controller ranges from 0.05 A to 0.08 A, approximately.

Do the values of the dc current at the PV panel, battery, and load indicate that the PV panel supplies all load current as well as the current charging the battery? Explain briefly.

Yes. $I_{Load} = I_{PV} + I_{Batt.}$ Consequently, $I_{PV} = I_{Load} - I_{Batt.}$ Since $I_{Batt.}$ is of negative polarity, it adds to I_{Load} .

- 24.** Compare the various values of the battery voltage and load voltage recorded so far. Do the battery voltage and load voltage vary slightly depending on whether the battery is charging or discharging?

Yes No

Yes

Battery charging

In this section, you will observe the operation of the PWM charge controller when the battery is charging. The nominal values of the voltage regulation (VR) and float voltage (V_{Float}) setpoints in the PWM charge controller are 56.8 V and 55.2 V, respectively.



Completion of this part of the procedure is considered optional because it takes some time (generally between 15 and 45 minutes depending on the actual state of charge of the battery). You should skip this part of the procedure if less than 1 hour remains in the lab session.

25. On the **DC 48V Lamps** module, turn the incandescent lamp off. This causes the battery current to increase to about 1.5 A because all the current produced by the PV panel now charges the battery.

On the PWM charge controller, observe the charging stage LED. It should continue to blink at a fast rate, thereby indicating that the controller is still in the bulk stage of battery charging.

In **LVDAC-EMS**, observe the battery voltage. It should increase slowly as the battery is charging.

26. In **LVDAC-EMS**, slowly decrease the solar irradiance of the solar panel emulator while making sure that you maintain enough solar irradiation to keep the battery charging, then set the solar irradiance back to 1000 W/m². While doing this, observe that the value of the battery charging current decreases when the solar irradiation decreases and vice versa. Briefly explain why.

This is because the PWM charge controller is in the bulk phase of battery charging. During this phase, the PWM charge controller does not control the battery charging current, i.e., all current produced by the PV panel is used to charge the battery. Consequently, the value of the battery charging current decreases when the solar irradiation decreases and vice versa.

27. Observe the charging stage LED on the PWM charge controller as well as the battery voltage indicated in **LVDAC-EMS**. The charging stage LED continues to blink at a fast rate as long as the PWM charge controller is in the bulk phase of battery charging. Also, the battery voltage continues to increase slowly throughout the bulk phase of battery charging.

Observe that after a certain time, the charging stage LED on the PWM charge controller stops blinking and lights up continuously. This indicates that the PWM charge controller is in the absorption stage of battery charging.



The duration of the bulk phase of battery charging depends on the actual state of charge of the battery. The lower the state of charge of the battery, the longer the duration of the bulk phase of battery charging.

28. In **LVDAC-EMS**, observe the battery voltage for 2 or 3 minutes. Does it continue to increase slowly as the battery is charging? Briefly explain why.

No. This is because, in the absorption stage of battery charging, the PWM charge controller adjusts the average value of the battery charging current so that the battery voltage remains at the voltage regulation (VR) setpoint.

29. Record the values of the battery voltage and load voltage indicated in LVDAC-EMS.

Battery voltage: _____ V

Load voltage: _____ V

Battery voltage: 56.9 V

Load voltage: 56.9 V

Does the measured battery voltage confirm that the PWM charge controller is in the absorption stage of battery charging? Explain briefly.

Yes, because the PWM charge controller maintains the battery voltage at 56.9 V, which is virtually equal to the nominal value (56.8 V) of the VR setpoint.

30. Observe the battery charging current indicated in LVDAC-EMS for 3 to 4 minutes. Does the value of the battery charging current decrease gradually as the battery is charging?



Current spikes in the battery charging current may exceed the maximum current (4 A) of current input I1 of the *Data Acquisition and Control Interface*. This causes clipping of the battery current measured by the *Data Acquisition and Control Interface*. The display of the battery current meter in LVDAC-EMS turns to yellow when clipping occurs.

Yes No

Yes

31. In LVDAC-EMS, slowly decrease the solar irradiance of the solar panel emulator to 900 W/m², then set it back to 1000 W/m². While doing this, observe that the value of the battery charging current remains virtually fixed. Briefly explain why.



If the value of the battery charging current varies when the solar irradiance is varied, let the system operate a few minutes and redo the manipulation above.

This is because the PWM charge controller is in the absorption phase of battery charging. During this phase, the PWM charge controller adjusts the average value of the battery charging current to maintain the battery voltage at the VR setpoint. Consequently, the value of the battery charging current is independent of the solar irradiation.

32. In LVDAC-EMS, stop the solar panel emulator. Observe that the charging stage LED on the PWM charge controller goes out to indicate that the battery is no longer charging.



Waiting for the PWM charge controller to enter the float stage of battery charging generally takes too much time. This is why battery charging is stopped at the absorption stage.

Comparing the energy consumption of two different types of dc lamps

In this section, you will compare the energy consumption of two dc lamps of different types (incandescent and LED) which produce approximately the same amount of light.

- 33.** On the **DC 48V Lamps** module, turn the incandescent lamp on.

In **LVDAC-EMS**, set a meter to measure power at the dc loads.

Record the incandescent lamp voltage, current, and power indicated in **LVDAC-EMS**.

Incandescent lamp voltage: _____ V

Incandescent lamp current: _____ A

Incandescent lamp power: _____ W

Incandescent lamp voltage: 51.1 V

Incandescent lamp current: 1.17 A

Incandescent lamp power: 59.8 W

Use the lamp power you just measured to calculate the daily energy demand of the incandescent lamp. Base your calculation on 4 hours of use per day.

Daily energy demand of the incandescent lamp: $59.8 \text{ W} \times 4 \text{ h} = 239.2 \text{ Wh}$

- 34.** Notice the amount of light which the incandescent lamp produces. On the **DC 48V Lamps** module, turn the incandescent lamp off, then turn the LED lamp on. Do the two lamps produce approximately the same amount of light?

Yes No

Yes

Record the LED lamp voltage, current, and power indicated in **LVDAC-EMS**.

LED lamp voltage: _____ V

LED lamp current: _____ A

LED lamp power: _____ W

LED lamp voltage: 51.6 V

LED lamp current: 0.181 A

LED lamp power: 9.34 W

Use the lamp power you just measured to calculate the daily energy demand of the LED lamp. Base your calculation on 4 hours of use per day.

Daily energy demand of the LED lamp: $9.34 \text{ W} \times 4 \text{ h} = 37.4 \text{ Wh}$

On the [DC 48V Lamps](#) module, turn the LED lamp off.

35. Compare the daily energy demand of the LED lamp with that of the incandescent lamp.

The daily energy demand of the LED lamp (37.4 Wh) is 6.4 times less than that of the incandescent lamp (239.2 Wh).

Does this confirm that the LED lamp is more efficient than the incandescent lamp at converting electricity into light? Explain briefly.

Yes. The LED lamp produces approximately the same amount of light as the incandescent lamp while consuming about 6 times less energy than the incandescent lamp.

Battery overdischarge protection

In this section, you will observe the operation of the battery overdischarge protection implemented in the PWM charge controller.

36. Disconnect the emulated PV panel from the PV system.

On the [48V Lead-Acid Battery Pack](#), open the circuit breaker by setting its lever to the *O* (off) position.

37. In [LVDAC-EMS](#), do the setting required to make the [4 Quadrant Power Supply and Dynamometer Controller](#) operate as a variable-voltage dc source. Then, set the dc source voltage to 51.2 V. This corresponds to the nominal open-circuit voltage of a 48 V lead-acid battery pack that is fully charged.

The output terminals of the power supply in the [Four-Quadrant Power Supply and Dynamometer Controller](#) are the terminals of the variable-voltage dc source.

At the moment, leave the variable-voltage dc source off.

38. Replace the battery in the PV system with the variable-voltage dc source implemented using the [4 Quadrant Power Supply and Dynamometer Controller](#). The equipment should be connected as shown in Figure 24.

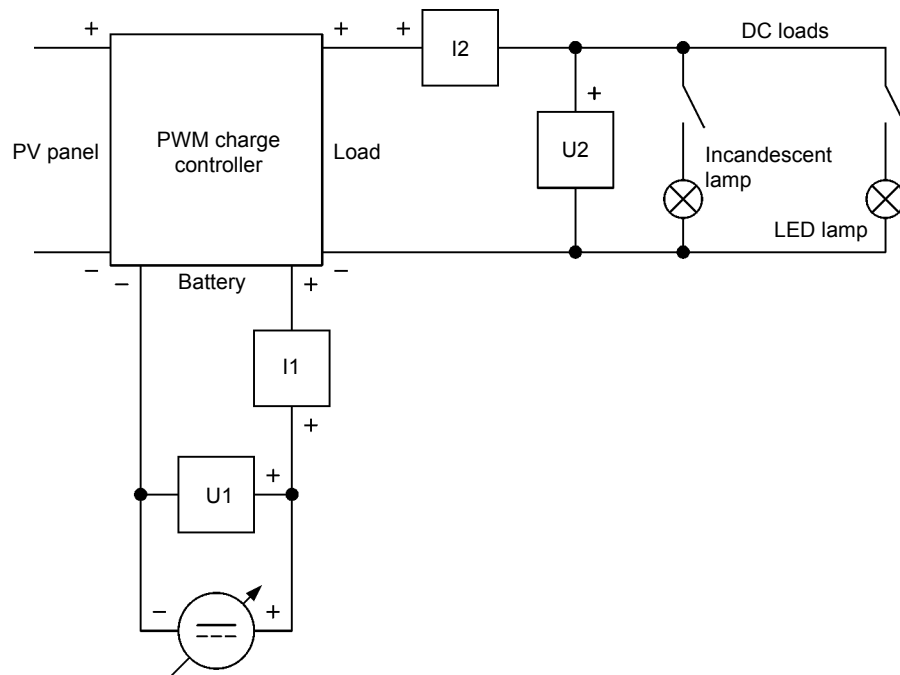

Figure 24. Circuit used to observe the operation of the battery discharge protection implemented in the PWM charge controller.

Varying the dc source voltage in the circuit above varies the voltage applied across the *Battery* terminals of the PWM charge controller. This allows the battery state of charge perceived by the PWM charge controller to be changed rapidly.

39. In *LVDAC-EMS*, turn the variable-voltage dc source on. The PWM charge controller should turn on as soon as the dc source is turned on. Also, the battery status LED on the PWM charge controller should light up in green because the dc source voltage is currently set to the value (51.2 V) of the nominal open-circuit voltage of a 48 V lead-acid battery pack that is fully charged.

On the *DC 48V Lamps* module, turn the incandescent lamp on.

40. In *LVDAC-EMS*, slowly decrease the dc source voltage to 43 V while observing the PWM charge controller. This decreases the voltage across the *Battery* terminals of the PWM charge controller, thereby emulating a battery whose state of charge becomes very low. In fact, the voltage across the *Battery* terminals is now below the low-voltage disconnect (LVD) setpoint (about 45 V) of the PWM charge controller.

Describe what happens.

When the voltage across the *Battery* terminals decreases to 43 V (i.e., below the LVD setpoint), the PWM charge controller detects that the battery state of charge is very low. Consequently, the battery status LED on the PWM charge controller passes from green to orange to red, then starts to blink in red to indicate that the battery is considered to be fully discharged. Also, the PWM charge controller disconnects the load (the incandescent lamp goes out) to stop battery discharge. The load status LED on the PWM charge controller goes out to indicate that the load has been disconnected.

Does the PWM charge controller achieve proper battery overdischarge protection?

Yes No

Yes

41. In LVDAC-EMS, slowly increase the dc source voltage to 53 V while observing the PWM charge controller. This increases the voltage across the *Battery* terminals of the PWM charge controller, thereby emulating a battery which is charging. In fact, the voltage across the *Battery* terminals now exceeds the low-voltage reconnect (LVR) setpoint (about 52 V) of the PWM charge controller.

Describe what happens.

When the voltage across the *Battery* terminals increases to 53 V (i.e., above the LVR setpoint), the PWM charge controller considers that the battery state of charge is sufficient to allow the load to be reconnected. Consequently, the battery status LED on the PWM charge controller lights up continuously (in green) to indicate that the battery is sufficiently charged. Also, the PWM charge controller reconnects the load (the incandescent lamp lights up). The load status LED on the PWM charge controller lights up to indicate that the load has been reconnected.

42. In LVDAC-EMS, turn the variable-voltage dc source off.

Close LVDAC-EMS.

43. Turn the 4 Quadrant Power Supply and Dynamometer Controller off.

Turn the AC 24V Power Supply off.

Turn electric power off at your workstation, if applicable. Remove all circuit connections, finishing with the equipment earthing connections. Return all equipment to its storage location.

CONCLUSION

In this exercise, you became familiar with the configuration and operation of stand-alone PV systems for dc loads. You learned how to use the specifications of the PV panel, charge controller, and battery selected for a specific stand-alone PV system to verify that they can work together without causing problems. You saw how the charge controller performs battery charging control and battery overdischarge protection. You also saw that choosing energy-efficient electric equipment (e.g., using LED lamps instead of incandescent lamps) is a means of reducing the size and cost of the stand-alone PV system for dc loads required in any application. You discovered several common applications of stand-alone PV systems for dc loads.

REVIEW QUESTIONS

1. What are the main functions of the charge controller in a stand-alone PV system?

The charge controller in a stand-alone PV system controls battery charging, prevents battery overcharging, and prevents the battery from being discharged too deeply.

2. The short-circuit current (I_{sc}) and open-circuit voltage (U_{oc}) of the PV panel in a stand-alone PV system are 7 A and 40 V, respectively. Voltage U_{oc} varies by $-0.4\%/^{\circ}\text{C}$. The maximum PV panel input current and maximum PV panel input voltage of the charge controller considered for the system are 10 A and 45 V. Assuming a minimum PV panel temperature of -15°C during normal system operation, can the charge controller work with the PV panel without problems? Explain briefly.

No, because the open-circuit voltage of the PV panel can cause a slight overvoltage at the PV panel input of the charge controller. When the PV panel temperature is at the minimum value (-15°C), the open-circuit voltage of the PV panel is 46.4 V [$40\text{ V} + (-40 \times -0.4\% \times 40\text{ V})$]. This slightly exceeds the maximum PV panel input voltage (45 V) of the charge controller.

3. Name three common applications of stand-alone PV systems for dc loads.

Common applications of stand-alone PV systems: electric power provision in small buildings, battery charging in recreational vehicles, refrigeration in developing countries, lighting of public spaces, road signaling.

4. The battery bank in a stand-alone PV system consists of four battery strings connected in parallel, each battery string consisting of two batteries connected in series. The voltage and capacity of each battery are 12 V and 80 Ah, respectively. What are the system voltage and the system capacity (i.e., the capacity of the battery bank)?

Each battery string consists of two 12 V batteries connected in series. The system voltage is thus 24 V ($2 \times 12\text{ V}$). The capacity of each of the four battery strings is 80 Ah. The system capacity is thus 320 Ah ($4 \times 80\text{ Ah}$).

5. What is the effect of using energy-efficient electric equipment on the size and cost of a stand-alone PV system for dc loads? Explain briefly.

Using electric equipment that is energy efficient, i.e., loads that require less power to perform the same task, reduces the daily energy demand. Reducing the energy demand allows the size, and thus the cost, of the stand-alone PV system required in any application to be reduced.

Bibliography

Masters, Gilbert M., Renewable and Efficient Electric Power Systems, Hoboken, New Jersey: John Wiley & Sons, 2004, ISBN 0-471-28060-7.

